

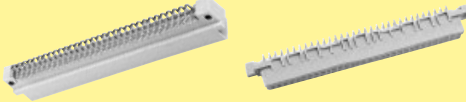

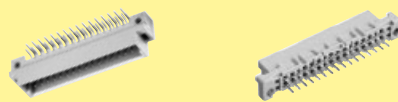



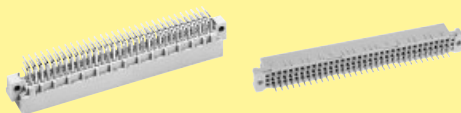

Types B, 2B, 3B, C, 2C, 3C, M, M invers, Q, 2Q, R, 2R

Page

Technical characteristics		01.10
Type B connectors		01.11
Type 2B connectors		01.16
Type 3B connectors		01.18
Type C connectors		01.20
Type 2C connectors		01.27
Type 3C connectors		01.32
Special contacts type M		01.36
Type M connectors		01.41
Type M-flat connectors		01.43
Type M invers connectors		01.44
Type R, RM, R (HE 11) connectors		01.46
Type Q, 2Q and 2R connectors		01.52
Pin shroud, adapter		01.57
Application examples		01.60

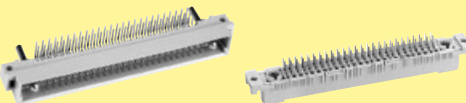
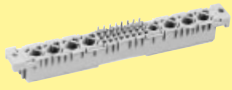
Number of contacts	16-96
Contact spacing (mm)	2.54
Working current see current carrying capacity chart	2 A max. 1 A with insulation displacement 40 A max. type M
Clearance	≥ 1.2 mm
Creepage	≥ 1.2 mm
Working voltage	according to the safety regulations of the equipment Explanations see chapter 00
The working voltage also depends on the clearance and creepage dimensions of the pcb itself, and the associated wiring	
Test voltage $U_{r.m.s.}$	1 kV
Contact resistance	≤ 15 mΩ for wire wrap and solder connection ≤ 20 mΩ including crimp connection
Insulation resistance	≥ 10 ¹² Ω for standard articles ≥ 10 ¹¹ Ω for special NFF articles (with part-no. ending 222)
Temperature range	- 55 °C ... + 125 °C - 40 °C ... + 105 °C for press-in connector
The higher temperature limit includes the local ambient and heating effects of the contacts under load	
During reflow soldering	max. + 240 °C for 15 s for SMC connectors
Degree of protection for crimp terminal according to DIN 40 050	IP 20
Electrical termination	
Male and female connector	Solder pins for pcb connections Ø 1.0 ± 0.1 mm according to IEC 60 326-3 wrap posts 0.6 x 0.6 mm diagonal 0.79-0.86 mm Crimp terminal 0.09-0.5 mm ² Insulation displacement connection AWG 28/7 Compliant press-in terminations
PCB thickness	≥ 1.6 mm
Recommended PCB holes for press-in technology	See recommendation page 00.25 in acc. to EN 60 352-5
Insertion and withdrawal force	16way ≤ 15 N 20way ≤ 20 N 30way ≤ 30 N 32way ≤ 30 N 48way ≤ 45 N 64way ≤ 60 N 96way ≤ 90 N
Materials	
Mouldings	Thermoplastic resin, glass-fibre filled, UL 94-V0
Contacts	Copper alloy
Contact surface	
Contact zone	Selectively plated according to performance level ¹⁾

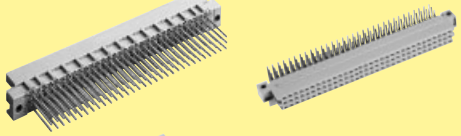
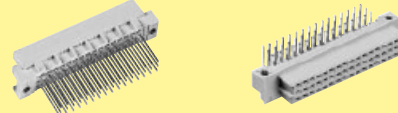
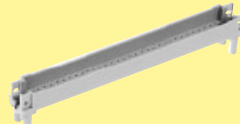
Current carrying capacity

The current carrying capacity is limited by maximum temperature of materials for inserts and contacts including terminals. The current capacity curve is valid for continuous, non interrupted current loaded contacts of connectors when simultaneous power on all contacts is given, without exceeding the maximum temperature.

Control and test procedures according to DIN IEC 60 512

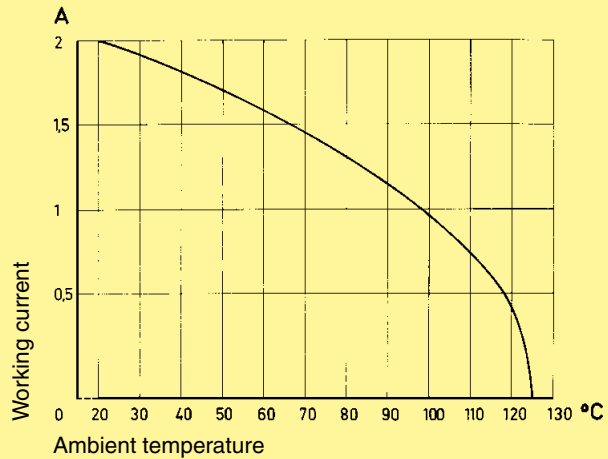

Pin shroud for female connectors with 0.6 x 0.6 mm pins

A secure interfacing system for signals from the rear of 19" racks to connectors with wrap posts 0.6 x 0.6 mm is possible with the use of a pin shroud.

The pin shroud protects the wrap posts on the rear side of the rack and can be screwed to the printed circuit board.

After assembly the rear ends of the wire wrap posts become the mating areas of the type C resp. type 2C male connector.

This system can now accept:

- female connectors type C
- female connectors type 2C
- female connectors type R
- female connectors type 2R

The locking levers provide security for the mated connectors. Fast and simple disconnection is possible (see application examples, pages 01.60 ff.

Fitting and removing crimp contacts

see technical characteristics chapter 02

¹⁾ Explanation performance levels see chapter 00

Mating conditions see chapter 00

Number of contacts

64, 32



Male connectors

DIN Signal
up to 2 A

Identification	Number of contacts	Contact arrangement	Part No. Performance levels according to IEC 60603-2. Explanation chapter 00		
			3	2	1
Male connector with angled solder pins	64		09 02 164 7921	09 02 164 6921 09 02 164 6921 222 ^{f)} 09 02 364 6921 ^{b)} 09 02 664 6921 ^{c)}	09 02 164 2921
	32		09 02 132 7921	09 02 132 6921 09 02 632 6921 ^{c)}	09 02 132 2921
	32		09 02 132 7931	09 02 132 6931 09 02 332 6931 ^{b)}	09 02 132 2931
	62 + 2 [▲]			09 02 164 6951	
SMC	64		09 02 164 7919 ^{d)}	09 02 164 6919 ^{d)}	
Male connector with straight solder pins	64		09 02 164 7922	09 02 164 6922	09 02 164 2922
	32		09 02 132 7922	09 02 132 6922	
	32			09 02 132 6932	
	62 + 2 [▲]			09 02 164 6952	09 02 164 2952
SMC	64			09 02 164 6920 ^{d)}	

Dimensions

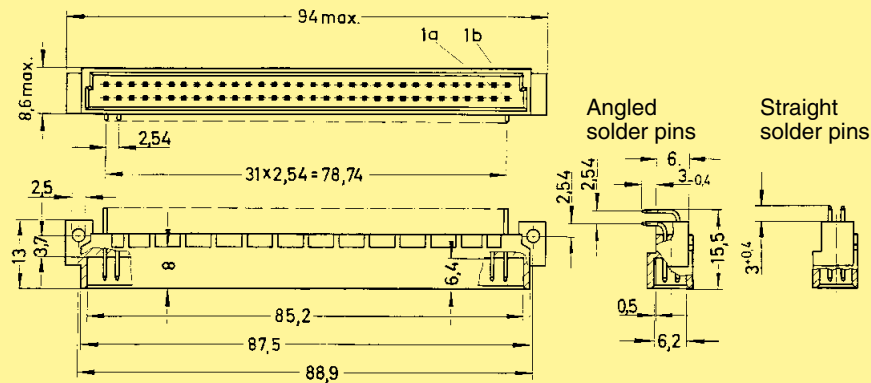

Board drillings

Mounting side

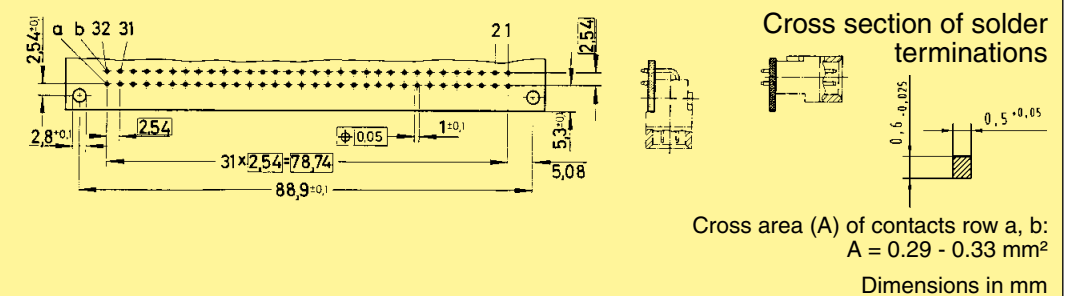

[▲] Male connectors with 2 leading contacts [(0.8 mm) pos. a1 and a32]. Lagging pins row b on request.
Other contact arrangements on request
^{b)} Connectors with snap-in clips see chapter 00

^{c)} Connectors with coding see chapter 00
^{d)} CTI > 400
^{f)} Railway classification NFF 16-101, Smoke index: F1, Flammability class: I2

Number of contacts

64

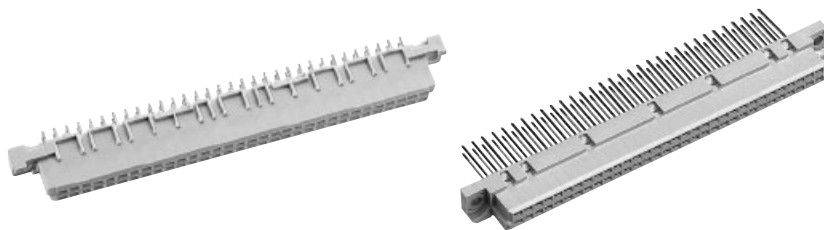

Female connectors

DIN Signal up to 2 A

Identification	Number of contacts	Contact arrangement	Part No.	Performance levels according to IEC 60 603-2. Explanation chapter 00	
			3	2 1	
Female connector with solder pins 2.9 mm	64		Performance level 3 on request	09 02 264 6824 09 02 464 6824 ^{b)} 09 02 764 6824 ^{c)}	09 02 264 2824
SMC	64			09 02 264 6841 ^{d)}	
Female connector with solder pins 4.5 mm	64			09 02 264 6825 09 02 264 6825 222 ^{f)} 09 02 464 6825 ^{b)} 09 02 764 6825 ^{c)}	09 02 264 2825
SMC	64			09 02 264 6829 ^{d)}	
Female connector with solder pins 13 mm	64			09 02 264 6421	
Female connector with press-in pins 4.5 mm	64			09 02 264 6850 09 02 264 6850 222 ^{f)}	09 02 264 2850
Female connector with press-in pins without flange 5.3 mm	64			09 02 264 6870	
Female connector with press-in pins 13.2 mm	64			09 02 264 6861 ^{a)}	
Female connector with wrap posts ¹⁾ 13 mm	64			09 02 264 6821	
Female connector with solder lugs 5.2 mm	64		09 02 264 6823		

01
12

1) To be used only for wire wrap termination
 a) Wrap posts selectively gold plated (performance level 3)
 b) Connectors with snap-in clips see chapter 00
 c) Connectors with coding see chapter 00

d) CTI > 400
 f) Railway classification NFF 16-101, Smoke index: F1, Flammability class: I2
 Other contact arrangements on request

Number of contacts

64



Female connectors

DIN Signal up to 2 A

Identification	Number of contacts	Part No.	Drawing	Dimensions in mm
Female connector for insulation displacement	64	Performance level 2 ¹⁾ 09 02 264 6828 Performance level 3 ¹⁾ 09 02 264 7828		
Strain relief (metal)		09 03 000 9940		
Panel cut out				
Flat cable AWG 28/7				²⁾ Termination area spacing = 508 mm Important: always store reels vertically
grey 30.48 m grey 100.00 m colour coded 30.48 m twisted pair ²⁾ 30.48 m	64 64 64 64	09 18 064 7001 09 18 064 7004 09 18 064 7005 09 18 064 7006	Wire (tinned) Gauge AWG 28/7 Insulation material as per UL style PVC	Cu AWG 28/7 0.089 mm ²
Round flat cable ³⁾				³⁾ Termination area spacing = 100 mm
with screening 30.48 m without screening 100.00 m	64 64	09 18 064 7007 09 18 064 7010 09 18 064 7008 09 18 064 7011		
Bench press		09 99 000 0114		
Base plate		09 99 000 0150		
Cable cutter		09 99 000 0116		
Spare parts				
Blade		09 99 000 0179		
Cutting plate		09 99 000 0180		

Number of contacts

max. 64

Female connectors

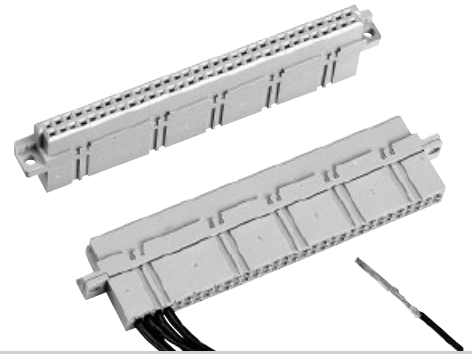

DIN Signal up to 2 A

Identification	Number of contacts	Part No.	Drawing	Dimensions in mm
Female connector for crimp contacts Order contacts separately	64	09 02 064 3214 ¹⁾	<p>Shell housing 09 02 064 0501 / 09 02 064 0502 see chapter 20</p>	

Identification	Part No.	Performance levels according to IEC 60603-2. Explanation chapter 00	
		2	1
Female crimp contacts BC			
Bandoliered contacts (approx. 5,000 pieces)	09 02 000 6484		09 02 000 6474
Bandoliered contacts (approx. 500 pieces)	09 02 000 8434		09 02 000 8444
Individual contacts ¹⁾	09 02 000 8484		09 02 000 8474
	Wire gauge mm ² AWG Insulation ø mm 0.09 - 0.5 28 - 20 0.7 - 1.5		<p>Bandoliered contacts</p>
	3.5 + 0.5 mm of insulation is stripped from the wires to be crimped For the fabrication in line with the specification please use exclusively crimp tools approved by HARTING (see DIN EN 60352-2) Insertion, removal and crimping tools see chapter 30		<p>Individual contacts</p>

¹⁾ Packaging unit 1,000 pieces
²⁾ Railway classification NFF 16-101, Smoke index: F1, Flammability class: I2

DIN 41 612 · complementary type 2B



Number of contacts

32, 16



Male connectors

DIN Signal up to 2 A

Identification	Number of contacts	Contact arrangement	Part No.	Performance levels according to IEC 60 603-2. Explanation chapter 00		
				3	2	1
Male connector with angled solder pins SMC	32		09 22 132 7921	09 22 132 6921 09 22 132 6921 222 ^{f)} 09 22 332 6921 ^{b)}	09 22 132 2921	
	32			09 22 132 6919 ^{d)} 09 22 332 6919 ^{b)} ^{d)}		
	16			09 22 116 6921		
	16		09 22 116 7931	09 22 116 6931		
	30 + 2 [▲]			09 22 132 6951		
Male connector with straight solder pins SMC	32		09 22 132 7922	09 22 132 6922	09 22 132 2922	
	32			09 22 132 6920 ^{d)}		

Dimensions

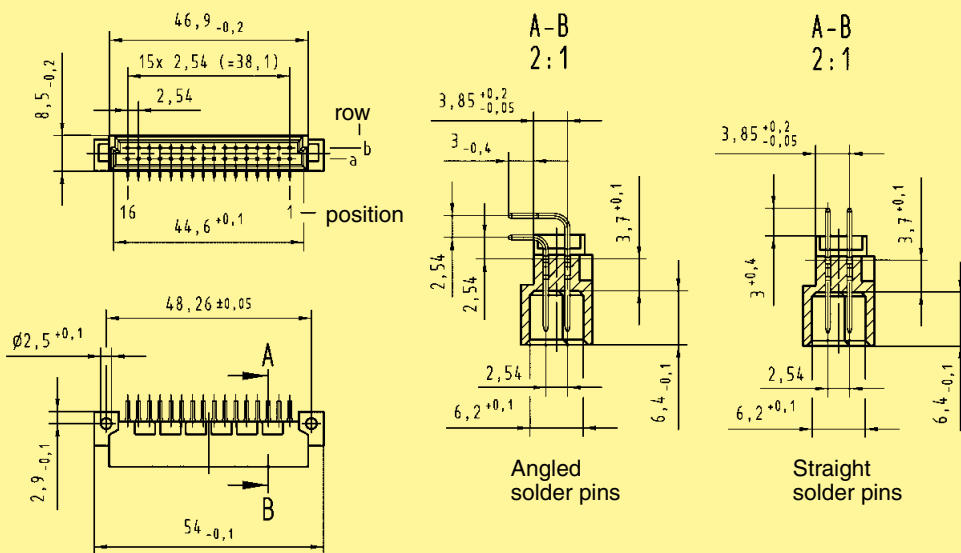

Board drillings

Mounting side

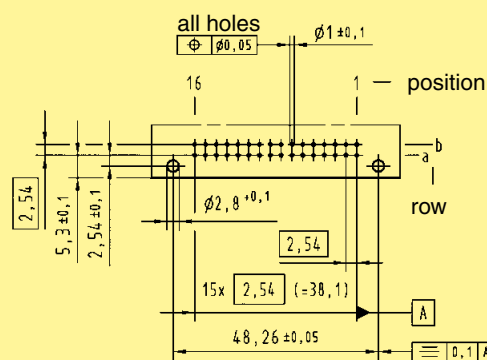

Cross section of solder terminations

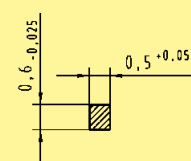

Cross area (A) of contacts row a, b: A = 0.29 - 0.33 mm²

Dimensions in mm

[▲] Male connectors with 2 leading contacts [(0.8 mm) pos. a1 and a16]. Lagging pins row b on request.

^{b)} Connectors with snap-in clips see chapter 00

^{d)} CTI > 400

^{f)} Railway classification NFF 16-101, Smoke index: F1, Flammability class: I2

Other contact arrangements on request

Number of contacts

20

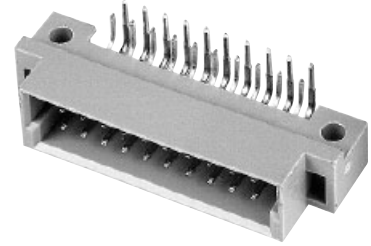

Male connectors

Identification	Number of contacts	Contact arrangement	Part No.	Performance levels according to IEC 60 603-2.		
			3	2	1	
Male connector with angled solder pins						
with fixing flange	20		Performance level 3 on request	09 24 120 6921	Performance level 1 on request	
with fixing flange, SMC	20			09 24 120 6919 ^{d)}		
without fixing flange	20			09 24 120 6571		
without fixing flange, SMC	20			09 24 120 6579 ^{d)}		

Dimensions

with fixing flange without fixing flange

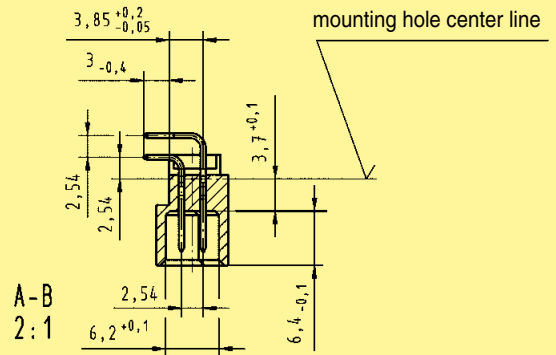
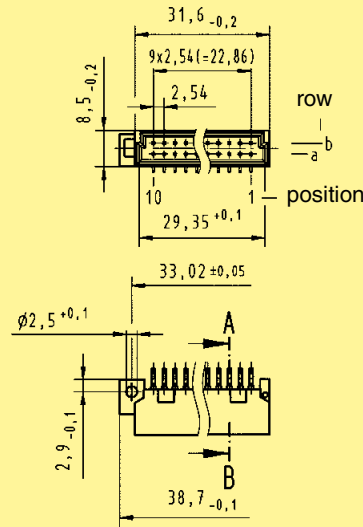

Board drillings

Mounting side

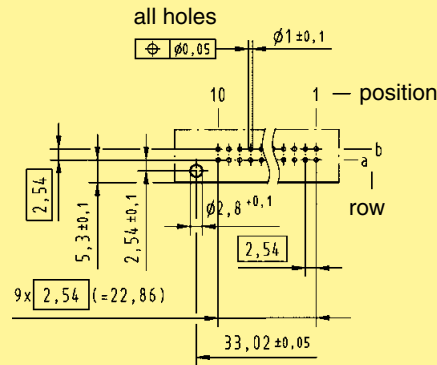

Cross section of solder terminations

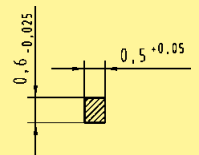

Cross area (A) of contacts
row a, b: A = 0.29 - 0.33 mm²

Dimensions in mm

Number of contacts

20

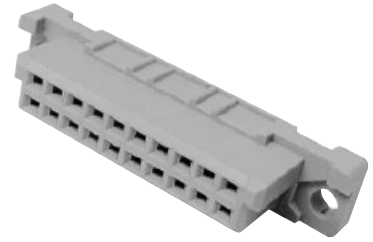

Female connectors

Identification	Number of contacts	Contact arrangement	Part No.	Performance levels according to IEC 60 603-2.		
				3	2	1
Female connector with solder pins 2.9 mm	20		Performance level 3 on request	09 24 220 6824	Performance level 1 on request	
with fixing flange				09 24 220 6841 ^{d)}		
without fixing flange, SMC				09 24 220 6414 ^{d)}		
Female connector with solder pins 4.5 mm	20		Performance level 3 on request	09 24 220 6825	Performance level 1 on request	
with fixing flange						
Female connector with press-in pins 4.5 mm	20		Performance level 3 on request	09 24 220 6850	Performance level 1 on request	
with fixing flange						
without fixing flange				09 24 220 6870		

DIN Signal up to 2 A

Dimensions

with fixing flange without fixing flange

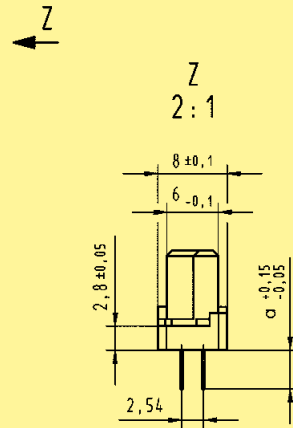
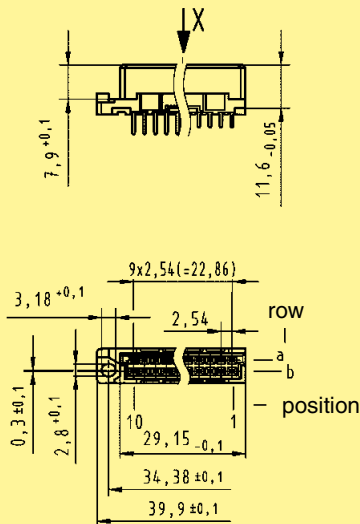

a	
2.9	solder pins
4.5	press-in pins

Board drillings

Mounting side

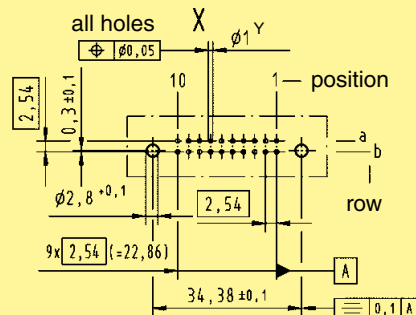

Cross section of solder terminations

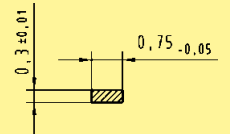

Cross area (A) of contacts row a, b, c: A = 0.20 - 0.23 mm²

Dimensions in mm

^{d)} CTI > 400

Number of contacts

96, 64, 32

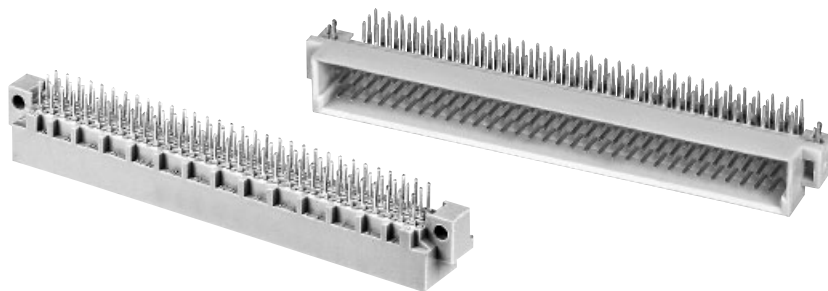

Male connectors

DIN Signal up to 2 A

Identification	Number of contacts	Contact arrangement	Part No.	Performance levels according to IEC 60 603-2. Explanation chapter 00		
				3	2	1
Male connector with angled solder pins	96		09 03 196 7921	09 03 196 6921	09 03 196 2921	
			09 03 396 7921 ^{b)}	09 03 196 6921 222 ^{f)}	09 03 196 2921 222 ^{f)}	
				09 03 396 6921 ^{b)}	09 03 396 2921 ^{b)}	
	SMC	96			09 03 696 6921 ^{c)}	09 03 696 2921 ^{c)}
					09 03 696 6921 222 ^{c)f)}	
					09 03 696 6921 222 ^{c)f)}	
	SMC	96			09 03 196 6919 ^{d)}	09 03 196 2919 ^{d)}
					09 03 396 6919 ^{b)d)}	09 03 396 2919 ^{b)d)}
					09 03 696 6919 ^{c)d)}	
	SMC	64		09 03 164 7921	09 03 164 6921	09 03 164 2921
				09 03 364 7921 ^{b)}	09 03 164 6921 222 ^{f)}	09 03 164 2921 222 ^{f)}
					09 03 364 6921 ^{b)}	09 03 364 2921 ^{b)}
SMC	64			09 03 664 6921 ^{c)}	09 03 664 2921 ^{c)}	
				09 03 164 6919 ^{d)}	09 03 164 2919 ^{d)}	
				09 03 364 6919 ^{b)d)}	09 03 364 2919 ^{b)d)}	
SMC	32		09 03 132 7921	09 03 132 6921	09 03 132 2921	
			09 03 332 7921 ^{b)}	09 03 332 6921 ^{b)}	09 03 332 2921 ^{b)}	
SMC	94 + 2 [▲]		09 03 196 7951	09 03 196 6951	09 03 196 2951	
				09 03 396 6951 ^{b)}		
				09 03 396 6918 ^{b)d)}		
SMC	94 + 2 [▲]					
SMC	62 + 2 [▲]		09 03 164 7951	09 03 164 6951	09 03 164 2951	
SMC	62 + 2 [▲]				09 03 164 2918 ^{d)}	
Male connector with straight solder pins	96		09 03 196 7922	09 03 196 6922	09 03 196 2922	
				09 03 196 6920 ^{d)}		
SMC	96					
SMC	64		09 03 164 7922	09 03 164 6922	09 03 164 2922	

[▲] Male connectors with 2 leading contacts [(0.8 mm) pos. a1 and a32]. Lagging pins row b on request.

^{b)} Connectors with snap-in clips see chapter 00

^{c)} Connectors with coding see chapter 00

^{d)} CTI > 400

^{f)} Railway classification NFF 16-101, Smoke index: F1, Flammability class: I2

Number of contacts

96, 64, 32

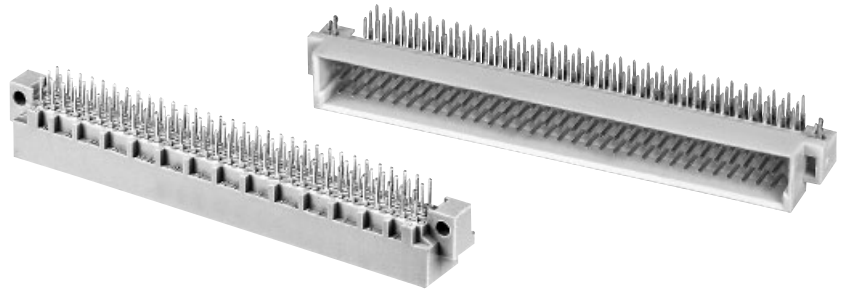

Male connectors

Dimensions

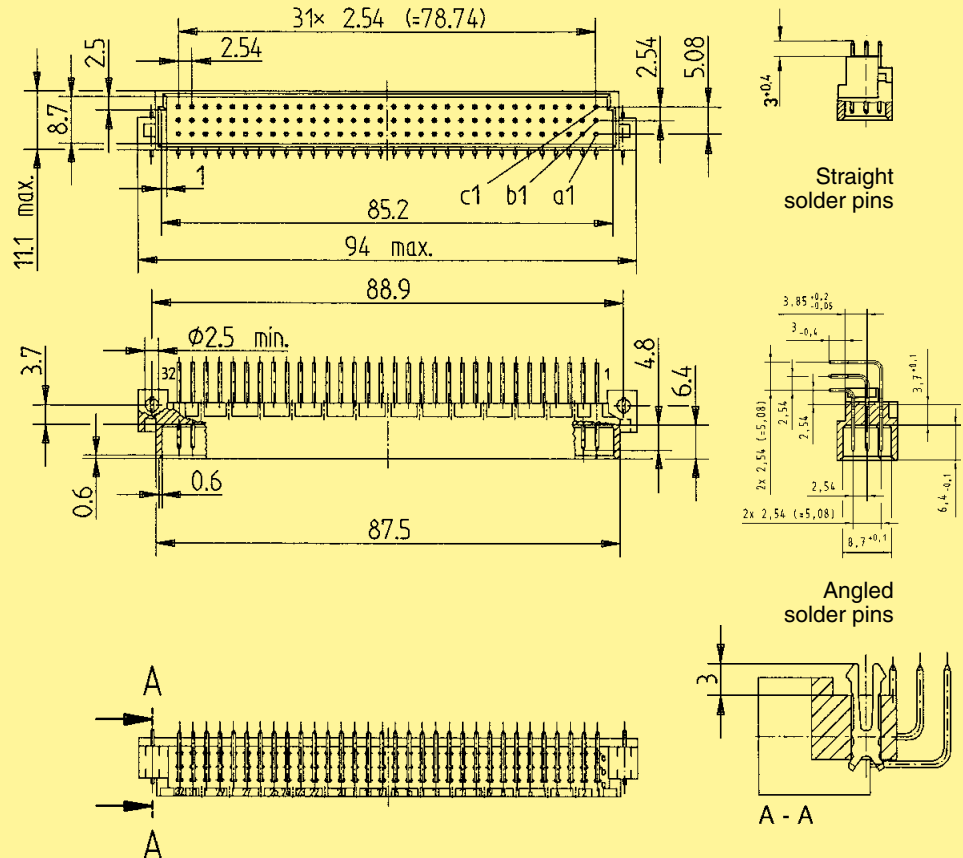

Board drillings
Mounting side

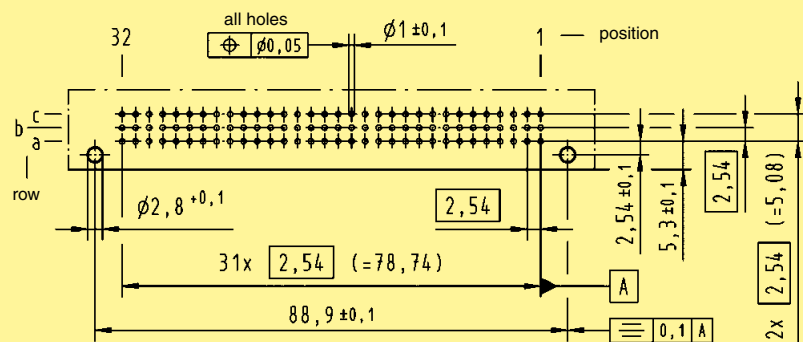

Cross section of solder terminations

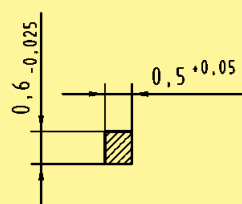

Cross area (A) of contacts row a, b, c: A = 0.29 - 0.33 mm²

Dimensions in mm

DIN Signal
up to 2 A

¹⁾ Recommendation for variants with clip: Drillings can be enlarged up to 3.1 mm ϕ to reduce standard mounting force

Number of contacts

96, 64, 32

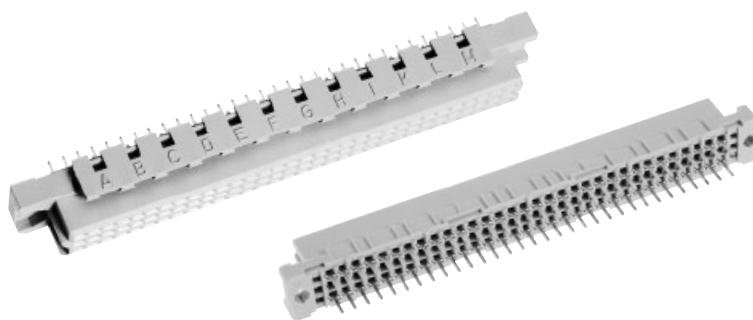

Female connectors

DIN Signal up to 2 A

Identification	Number of contacts	Contact arrangement	Part No. Performance levels according to IEC 60 603-2. Explanation chapter 00		
			3	2	1
Female connector with solder pins 2.9 mm	96		09 03 296 7824	09 03 296 6824 09 03 296 6824 222 ^{f)} 09 03 496 6824 ^{b)} 09 03 796 6824 ^{c)}	09 03 296 2824 09 03 496 2824 ^{b)}
				09 03 296 6841 ^{d)}	
	64		09 03 264 7824	09 03 264 6824 09 03 264 6824 222 ^{f)} 09 03 464 6824 ^{b)} 09 03 764 6824 ^{c)}	09 03 264 2824 09 03 464 2824 ^{b)}
				09 03 264 6841 ^{d)}	
Female connector with kinked solder pins ¹⁾ 2.9 mm	96		09 03 296 7855	09 03 296 6855	09 03 296 2855
	64		09 03 264 7855	09 03 264 6855	09 03 264 2855
	32		09 03 232 7855	09 03 232 6855	09 03 232 2855
Female connector with solder pins 4.5 mm	96		09 03 296 7825	09 03 296 6825 09 03 296 6825 222 ^{f)} 09 03 496 6825 ^{b)} 09 03 796 6825 ^{c)} 09 03 796 6825 222 ^{c)f)}	09 03 296 2825 222 ^{f)} 09 03 796 2825 ^{c)}
				09 03 296 6829 ^{d)}	
	64		09 03 264 7825	09 03 264 6825 09 03 464 6825 ^{b)} 09 03 764 6825 ^{c)}	09 03 264 2825
				09 03 264 6829 ^{d)}	
	32		09 03 232 7825	09 03 232 6825	09 03 232 2825
Female connector with kinked solder pins ¹⁾ 4.5 mm	96		09 03 296 7845	09 03 296 6845	09 03 296 2845
	64		09 03 264 7845	09 03 264 6845	09 03 264 2845
	32		09 03 232 7845	09 03 232 6845	09 03 232 2845
Female connector with solder pins 13 mm	96			09 03 296 6421 09 03 796 6421 ^{c)}	
	64			09 03 264 6421 09 03 764 6421 ^{c)}	
	32			09 03 232 6421 09 03 732 6421 ^{c)}	

¹⁾ Kinked pins for fixing the connector onto the pcb see chapter 00

^{b)} Connectors with snap-in clips see chapter 00

^{c)} Connectors with coding see chapter 00

^{d)} CTI > 400

^{f)} Railway classification NFF 16-101, Smoke index: F1, Flammability class: I2

Number of contacts

96, 64, 32

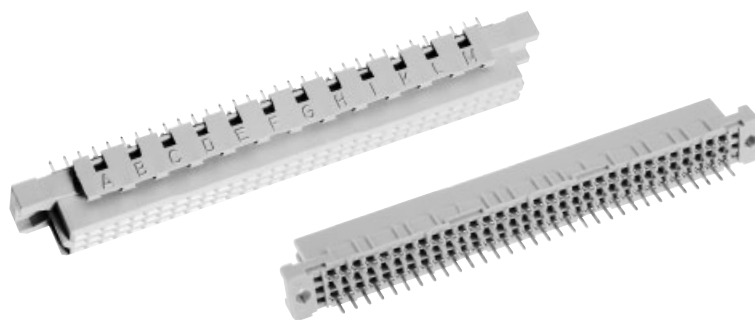

Female connectors

Identification

Drawing

Dimensions in mm

Dimensions

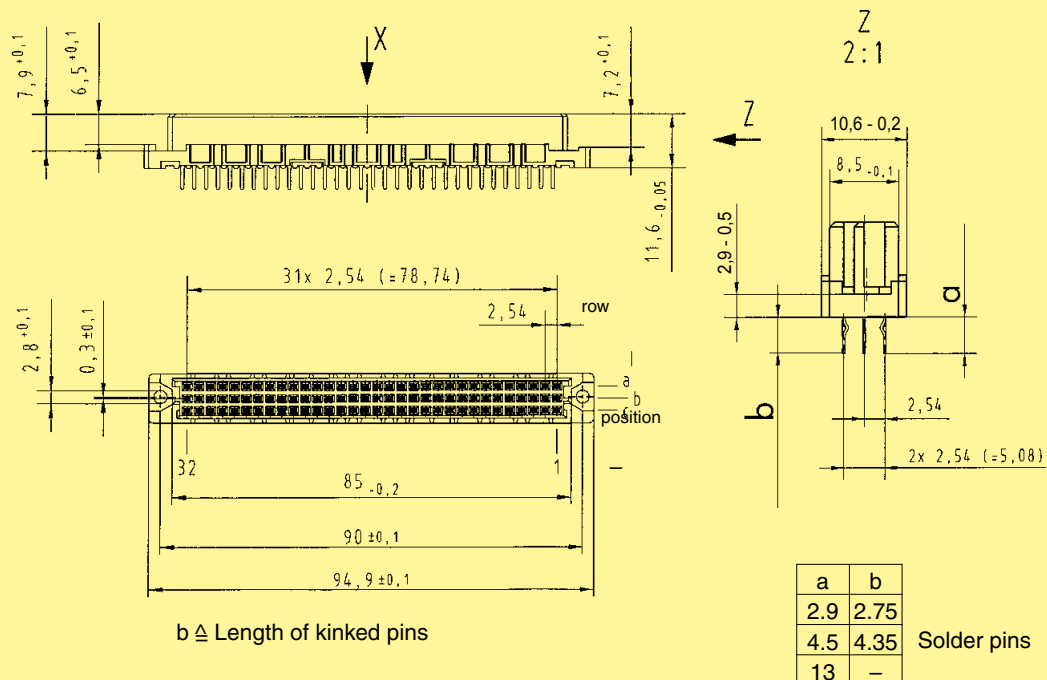

Board drillings
Mounting side

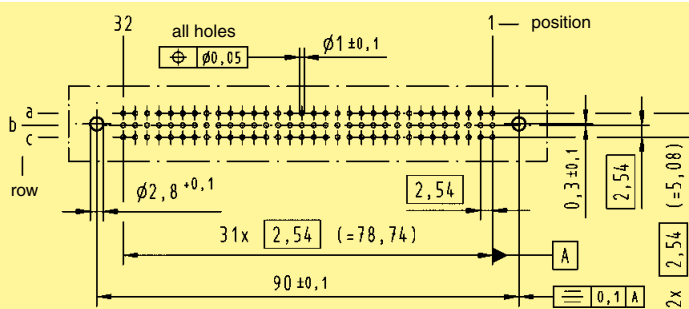

Cross section of solder terminations

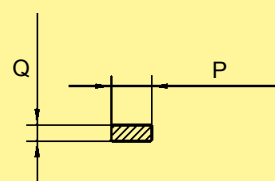

Cross area (A) of contacts

a	P	Q	A
2.9	0.75 _{-0.05}	0.30 _{±0.01}	0.20 - 0.23 mm ²
4.5	0.75 _{-0.05}	0.30 _{±0.01}	0.20 - 0.23 mm ²
13	0.60 _{-0.02}	0.60 _{-0.02}	0.33 - 0.38 mm ²

Dimensions in mm

DIN Signal
up to 2 A

Number of contacts

96, 64, 32

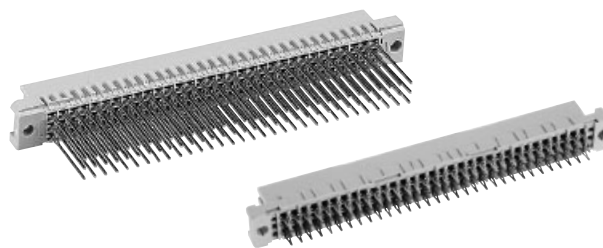

Female connectors

DIN Signal up to 2 A

Identification	Number of contacts	Contact arrangement	Part No. Performance levels according to IEC 60 603-2. Explanation chapter 00					
			3	2	1			
Female connector Type C with press-in terminations 4.5 mm	96		09 03 296 7850	09 03 296 6850 09 03 296 6850 222 ^{f)} 09 03 796 6850 ^{c)} 09 03 796 6850 222 ^{c)f)}	09 03 296 2850 09 03 296 2850 222 ^{f)}			
						09 03 264 7850	09 03 264 6850	09 03 264 2850
	13.2 mm	96		09 03 296 7850	09 03 296 6851 09 03 296 6861*			
		64					09 03 264 7850 09 03 264 6861*	
	17 mm	96		09 03 232 7850	09 03 232 6850	09 03 232 2850		
					09 03 296 6852 09 03 296 6862*			

Dimensions

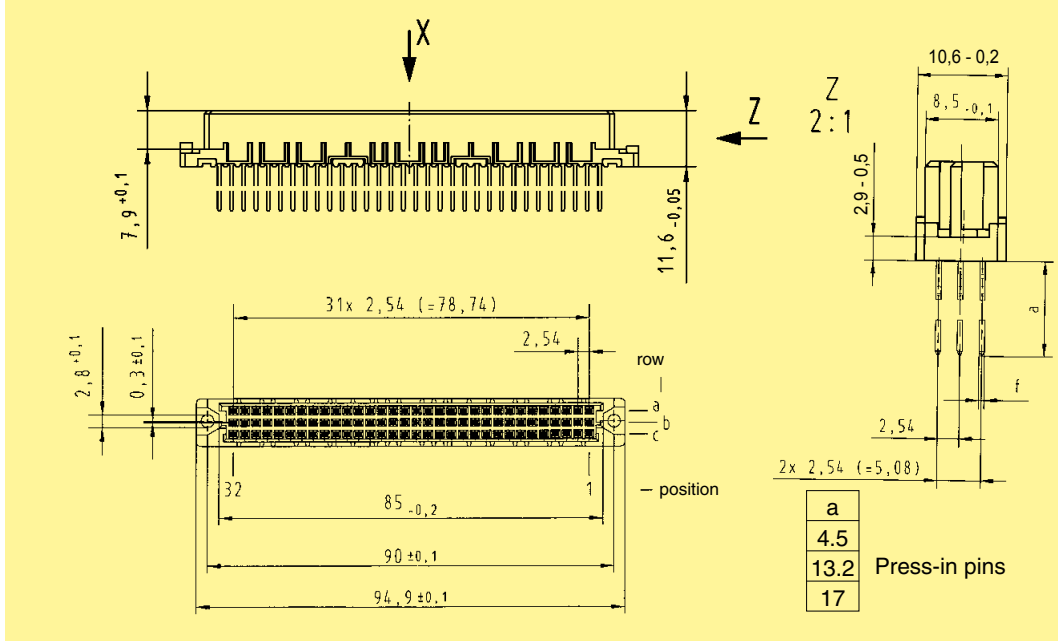

Board drillings

Mounting side

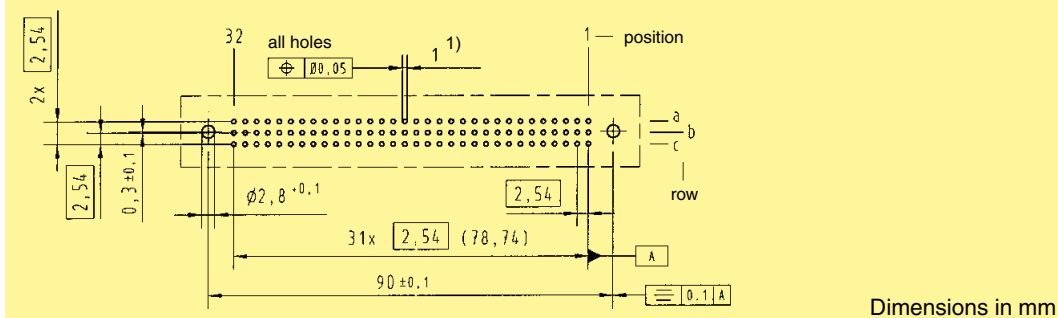

Dimensions in mm

* Wrap posts for interfacing selectively gold plated (performance level 3)

Other contact arrangements on request

¹⁾ refer to recommended configuration of pcb holes, see page 00.25

^{c)} Connectors with coding see chapter 00

^{f)} Railway classification NFF 16-101, Smoke index: F1, Flammability class: I2

Number of contacts

96, 64

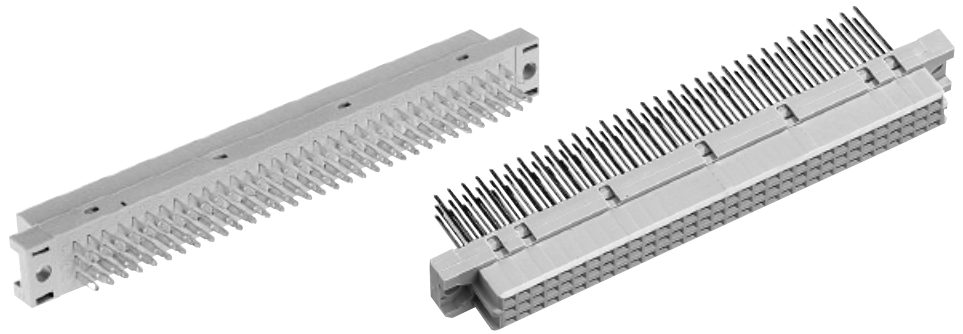

Female connectors

Identification	Number of contacts	Contact arrangement	Part No.	Performance levels according to IEC 60603-2. Explanation chapter 00		
				3	2	1
Female connector with wrap posts ²⁾ 13 mm	96		Performance level 3 on request	09 03 296 6821	Performance level 1 on request	
	64			09 03 796 6821 ^{c)} 09 03 296 6878 ¹⁾		
Female connector with solder lugs a + c 5.2 mm b 7.7 mm	96			09 03 264 6821		
	64			09 03 764 6821 ^{c)} 09 03 264 6878 ¹⁾		
	96			09 03 296 6823		
	64			09 03 796 6823 ^{c)} 09 03 264 6823 09 03 764 6823 ^{c)}		

DIN Signal up to 2 A

Dimensions

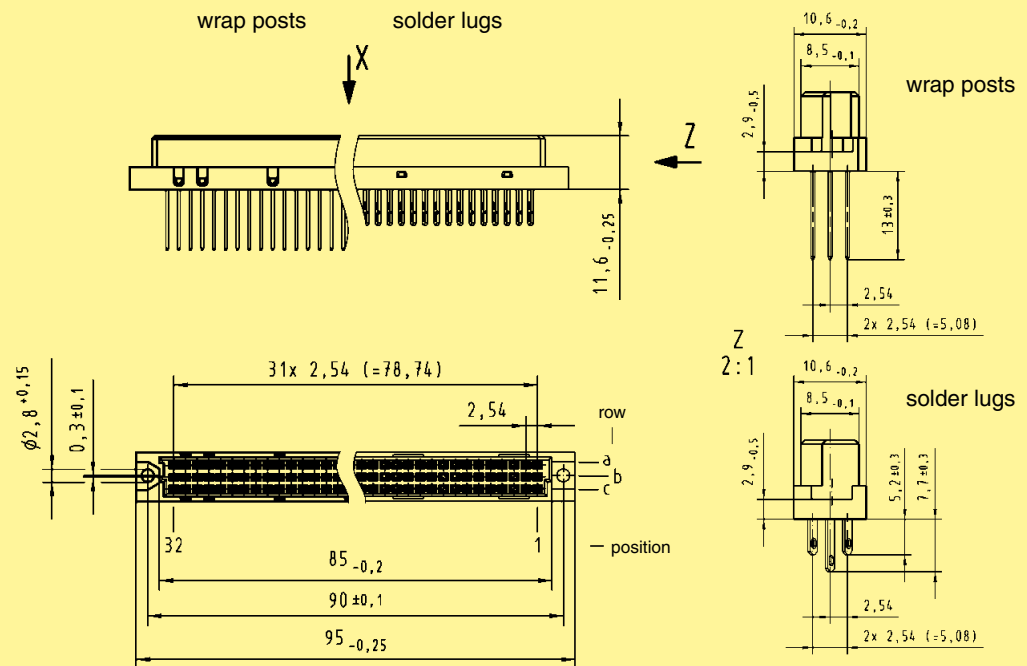

Panel cut out

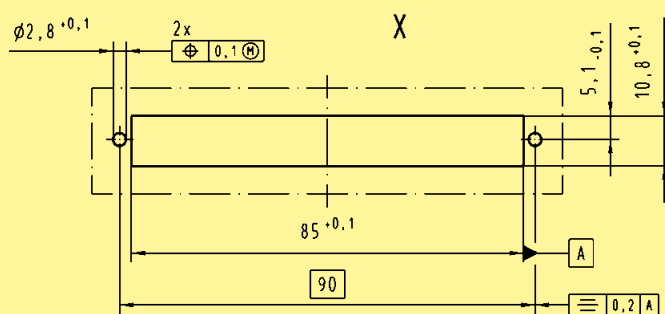

Identification strips for female connectors with wrap posts
09 03 000 9939

Dimensions in mm

¹⁾ Wrap posts for interfacing, selectively gold-plated (performance level 3)
²⁾ To be used only for wire wrap termination. Solder versions see page 01.22
^{c)} Connectors with coding see chapter 00

Number of contacts

64



Female connectors

DIN Signal up to 2 A

Identification	Number of contacts	Part No.	Drawing	Dimensions in mm
----------------	--------------------	----------	---------	------------------

Female connector for insulation displacement

64

Performance level 2¹⁾
09 03 264 6828
09 03 764 6828^{c)}

Performance level 3¹⁾
09 03 264 7828

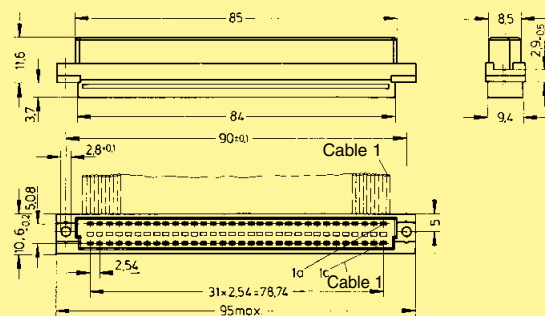

Cable 1 to contact 1 c
Contact arrangement View from termination side

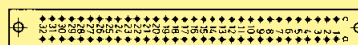

Strain relief (metal)

09 03 000 9940

Panel cut out

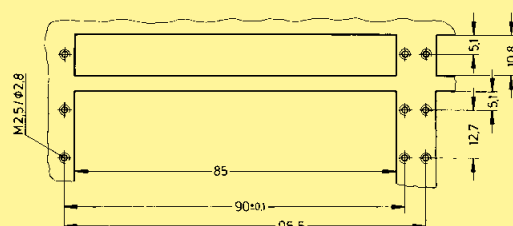

Mateable with 3 row male connector type C, no female contacts in the middle row

Flat cable
AWG 28/7

grey	30.48 m	64	09 18 064 7001
grey	100.00 m	64	09 18 064 7004
colour coded	30.48 m	64	09 18 064 7005
twisted pair ²⁾	30.48 m	64	09 18 064 7006

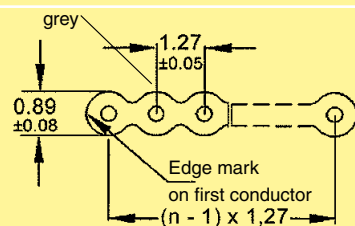

²⁾ Termination area spacing = 508 mm

Important: always store reels vertically

Wire (tinned) Gauge Insulation material as per UL style

Cu AWG 28/7 0.089 mm² PVC

Round flat cable³⁾

with screening	30.48 m	64	09 18 064 7007
	100.00 m	64	09 18 064 7010
without screening	30.48 m	64	09 18 064 7008
	100.00 m	64	09 18 064 7011

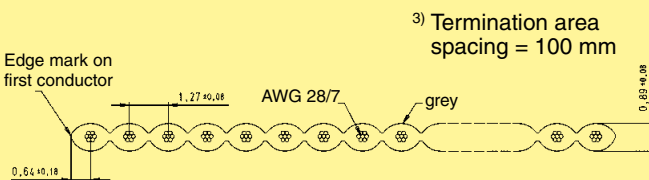

³⁾ Termination area spacing = 100 mm

Bench press
Base plate

09 99 000 0114
09 99 000 0150

Cable cutter

09 99 000 0116

Spare parts
Blade
Cutting plate

09 99 000 0179
09 99 000 0180



Number of contacts

max. 96, 48

Female connectors

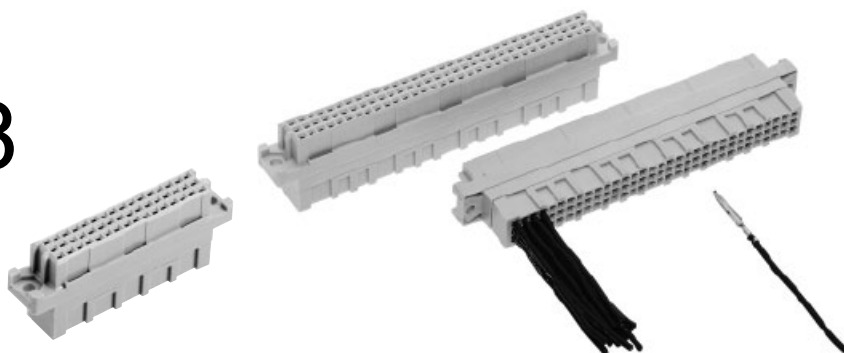

DIN Signal up to 2 A

Identification	Number of contacts	Part No.	Drawing type C	Dimensions in mm
Female connector for crimp contacts Order contacts separately Type C	96	09 03 096 3214 ^{d)} 09 03 596 3214 ^{c)f)}	<p>Technical drawing showing dimensions: 84,95 ±0,05, 83,95 ±0,05, 10,9 ±0,1, 11,55 ±0,05, 8,45 ±0,05, 2,8 ±0,05, 9,98 ±0,05, 31x2,54 (=78,74), 2,54, 2,54, 2x2,54 (=5,08), 90 ±0,1, 94,8 ±0,1, 32, 32, 31, 30, 29, 28, 27, 26, 25, 24, 23, 22, 21, 20, 19, 18, 17, 16, 15, 14, 13, 12, 11, 10, 9, 8, 7, 6, 5, 4, 3, 2, 1.</p> <p>Shell housing see chapter 20</p>	
Type C Position marking turned for mating type R male	96	09 03 096 3217 ^{d)}		
Type 2C	48	09 23 048 3214 ^{d)}		

Identification	Part No.	Performance levels according to IEC 60 603-2. Explanation chapter 00
	2	1
Female crimp contacts BC Bandoliered contacts (approx. 5.000 pieces)	09 02 000 6484	09 02 000 6474
Bandoliered contacts (approx. 500 pieces)	09 02 000 8434	09 02 000 8444
Individual contacts ¹⁾	09 02 000 8484	09 02 000 8474

Wire gauge mm² AWG Insulation ø mm
 0.09 - 0.5 28 - 20 0.7 - 1.5

3.5 + 0.5 mm of insulation is stripped from the wires to be crimped
 For the fabrication in line with the specification please use exclusively crimp tools approved by HARTING (see DIN EN 60352-2)
 Insertion, removal and crimping tools see chapter 30

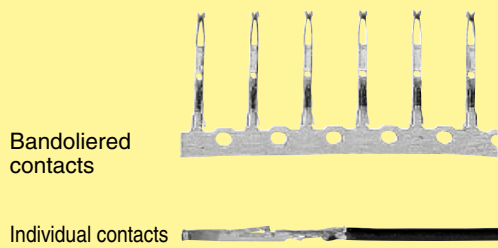

^{d)} Connectors with coding see chapter 00
¹⁾ Packaging unit 1,000 pieces
^{f)} Railway classification NFF 16-101, Smoke index: F1, Flammability class: I2

Number of contacts

48, 32, 16

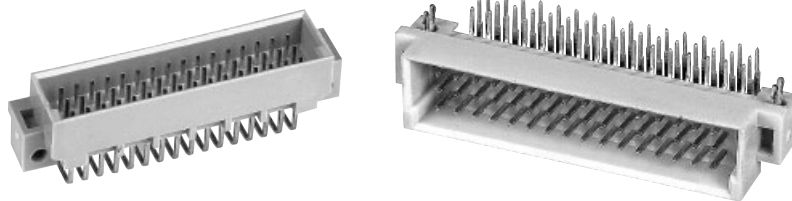

Male connectors

DIN Signal up to 2 A

Identification	Number of contacts	Contact arrangement	Part No.	Performance levels according to IEC 60 603-2. Explanation chapter 00		
				3	2	1
Male connector with angled solder pins	48		09 23 148 7921	09 23 148 6921	09 23 148 2921	
			09 23 348 7921 ^{b)}	09 23 148 6921 222 ^{f)}	09 23 348 6921 ^{b)}	
	SMC 48		09 23 148 7919	09 23 148 6919 ^{d)}	09 23 148 2919 ^{d)}	
				09 23 348 6919 ^{b)d)}	09 23 348 2919 ^{b)d)}	
	SMC 32		09 23 132 7921	09 23 132 6921	09 23 132 2921	
			09 23 332 7921 ^{b)}	09 23 332 6921 ^{b)}		
	SMC 32			09 23 132 6919 ^{d)}	09 23 132 2919 ^{d)}	
			09 23 332 6919 ^{b)d)}	09 23 332 2919 ^{b)d)}		
16				09 23 116 2921		
16		09 23 116 7931	09 23 116 6931	09 23 116 2931		
			09 23 316 6931 ^{b)}			
	46 + 2 [▲]		09 23 148 7951	09 23 148 6951	09 23 148 2951	
				09 23 348 6951 ^{b)}		
Male connector with straight solder pins	48		09 23 148 7922	09 23 148 6922	09 23 148 2922	
	SMC 48					
				09 23 148 6920 ^{d)}		
	SMC 32		09 23 132 7922	09 23 132 6922	09 23 132 2922	
	SMC 32			09 23 132 6920 ^{d)}		

▲ Male connectors with 2 leading contacts [(0.8 mm) pos. a1 and a16]. Lagging pins row b on request.
Other contact arrangements on request
^{b)} Connectors with snap-in clips see chapter 00

^{d)} CTI > 400
^{f)} Railway classification NFF 16-101, Smoke index: F1, Flammability class: I2

Number of contacts

48, 32, 16

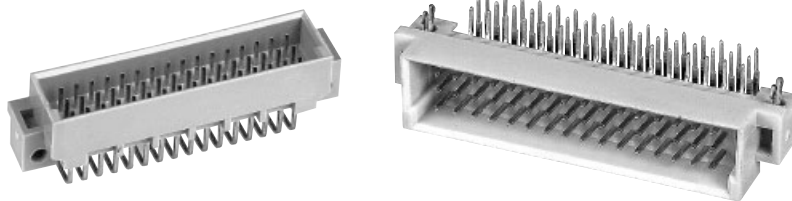

Male connectors

Identification

Drawing

Dimensions in mm

Dimensions

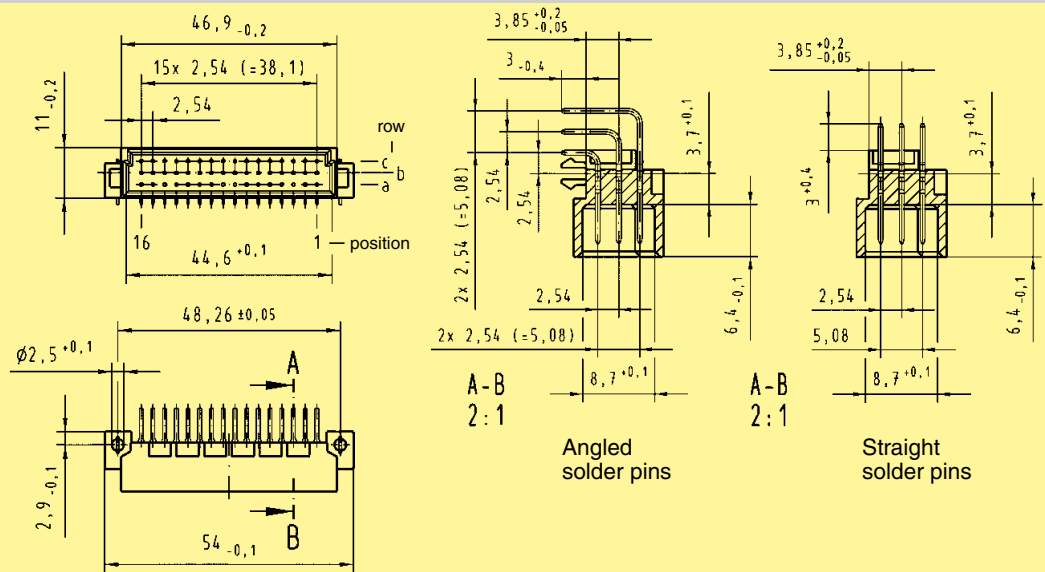

Board drillings

Mounting side

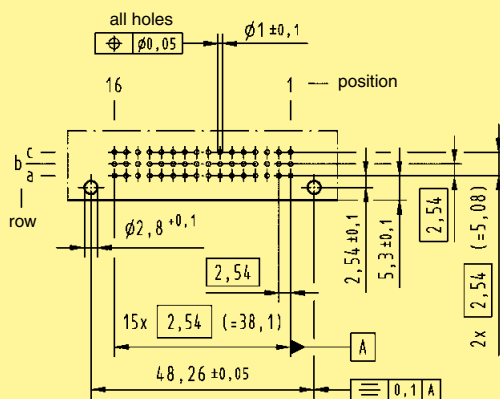

Cross section of solder terminations

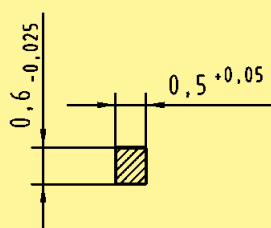

Cross area (A) of contacts row a, b, c: A = 0.29 - 0.33 mm²

DIN Signal
up to 2 A

¹⁾ Recommendation for variants with clip: Drillings can be enlarged up to 3.1 mm ø to reduce standard mounting force

Number of contacts

48, 32

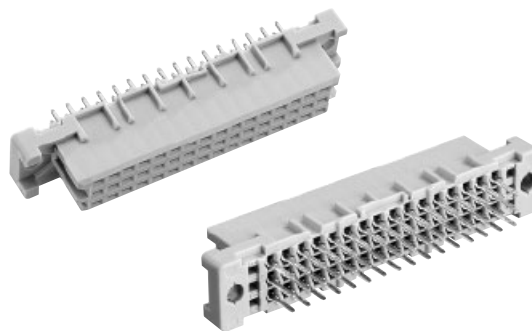

Female connectors

DIN Signal up to 2 A

Identification	Number of contacts	Contact arrangement	Part No.	Performance levels according to IEC 60 603-2. Explanation chapter 00		
				3	2	1
Female connector with solder pins 2.9 mm	48			09 23 248 6824 09 23 248 6824 222 ^{f)} 09 23 448 6824 ^{b)}	09 23 248 2824	
		SMC		09 23 248 6841 ^{d)}		
	32			09 23 232 6824 09 23 432 6824		
		SMC		09 23 232 6841 ^{d)}		
Female connector with solder pins 4.5 mm	48			09 23 248 6825 09 23 248 6825 222 ^{f)} 09 23 448 6825 ^{b)}	09 23 248 2825	
		SMC		09 23 248 6829 ^{d)}		
	32		09 23 232 7825	09 23 232 6825		
	SMC			09 23 232 6829 ^{d)}		
Female connector with solder pins 13 mm	48			09 23 248 6421		
Female connector with press-in pins 3.7 mm	48			09 23 248 6866		
Female connector with press-in pins 4.5 mm	48			09 23 248 6850 09 23 248 6850 222 ^{f)}	09 23 248 2850	
	32			09 23 232 6850		
Female connector with wrap posts ¹⁾ 13 mm	48			09 23 248 6821		
Female connector with solder lugs 5.2 mm	32			09 23 232 6823		

Other contact arrangements on request

¹⁾ To be used only for wire wrap termination

^{b)} Connectors with snap-in clips see chapter 00

^{d)} CTI > 400

^{f)} Railway classification NFF 16-101, Smoke index: F1, Flammability class: I2

Number of contacts

48, 32

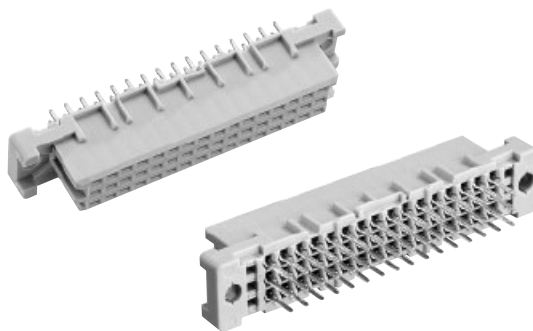

Female connectors

Identification Number of contacts Contact arrangement Part No. Performance levels according to IEC 60603-2. Explanation chapter 00

Dimensions

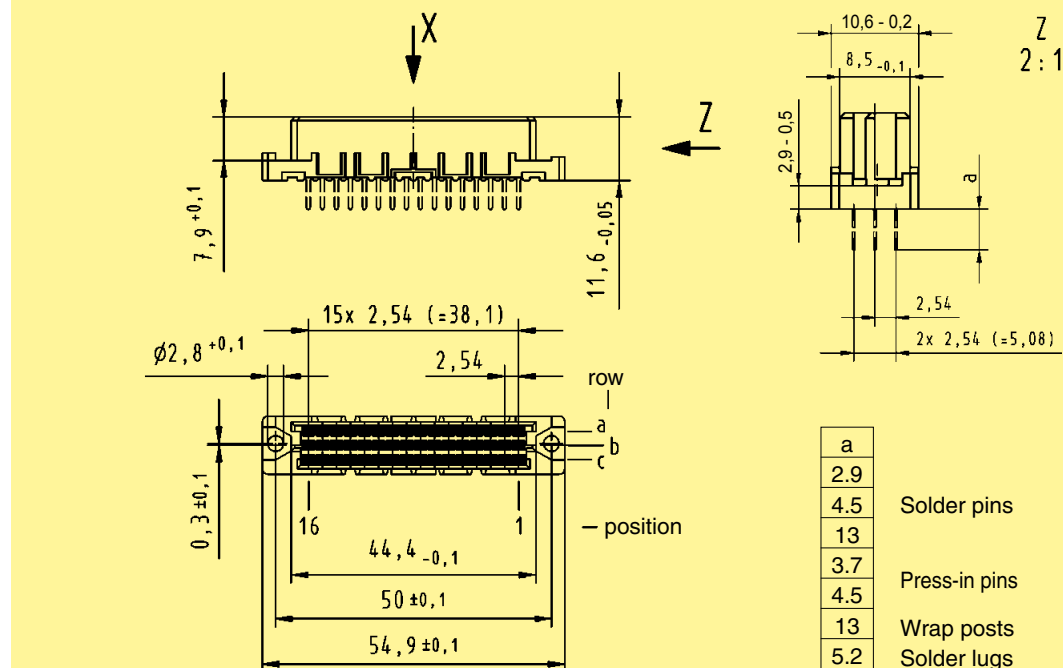

Board drillings
Mounting side

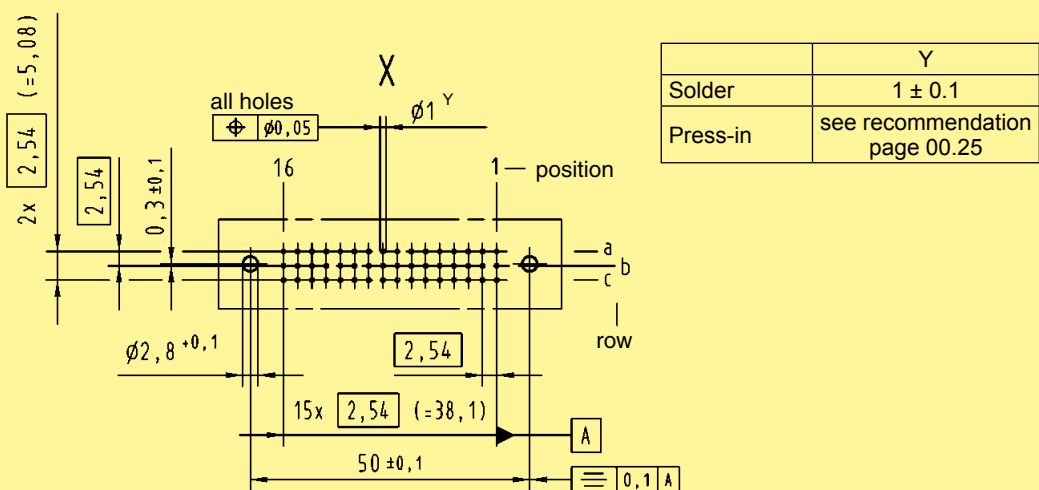

Cross section of solder terminations

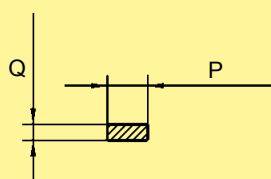

a	P	Q	A
2.9	0.75 _{-0.05}	0.30 _{±0.01}	0.20 - 0.23 mm ²
4.5	0.75 _{-0.05}	0.30 _{±0.01}	0.20 - 0.23 mm ²
13	0.60 _{-0.02}	0.60 _{-0.02}	0.33 - 0.38 mm ²

Cross area (A) of contacts

Dimensions in mm

DIN Signal
up to 2 A

Number of contacts

30, 20

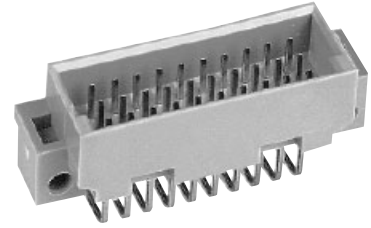

Male connectors

DIN Signal
up to 2 A

Identification	Number of contacts	Contact arrangement	Part No.	Performance levels according to IEC 60 603-2.					
			3	2	1				
Male connector with angled solder pins	with fixing flange		Performance level 3 on request	Performance level 2	Performance level 1				
		30				09 25 130 6921			
		20				09 25 120 6921			
	with fixing flange, SMC	30				09 25 130 6919 ^{d)}			
	without fixing flange	30				09 25 130 6571			
without fixing flange, SMC	30	09 25 130 6579 ^{d)}							
Male connector with straight solder pins	with fixing flange					Performance level 3 on request	Performance level 2	Performance level 1	
		30							09 25 130 6922
		20							09 25 120 6922
	without fixing flange	30							09 25 130 6572
	without fixing flange, SMC	30	09 25 130 6590 ^{d)}						

^{d)} CTI > 400

Number of contacts

30, 20

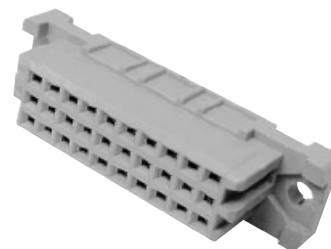

Female connectors

DIN Signal up to 2 A

Identification	Number of contacts	Contact arrangement	Part No.	Performance levels according to IEC 60 603-2.					
			3	2	1				
Female connector with solder pins 2.9 mm	with fixing flange		Performance level 3 on request	Performance level 1 on request	09 25 230 6824				
					09 25 220 6824				
	with fixing flange, SMC				09 25 230 6841 ^{d)}				
	without fixing flange, SMC				09 25 230 6414 ^{d)}				
Female connector with solder pins 4.5 mm	with fixing flange				Performance level 3 on request	Performance level 1 on request	09 25 230 6825		
							09 25 220 6825		
Female connector with press-in pins 4.5 mm	with fixing flange						Performance level 3 on request	Performance level 1 on request	09 25 230 6850
	without fixing flange								09 25 230 6870

^{d)} CTI > 400

Number of contacts

30, 20

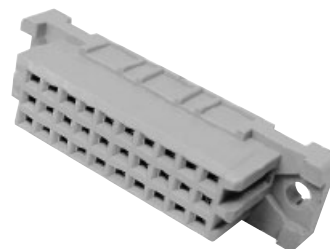

Female connectors

Identification

Drawing

Dimensions in mm

Dimensions

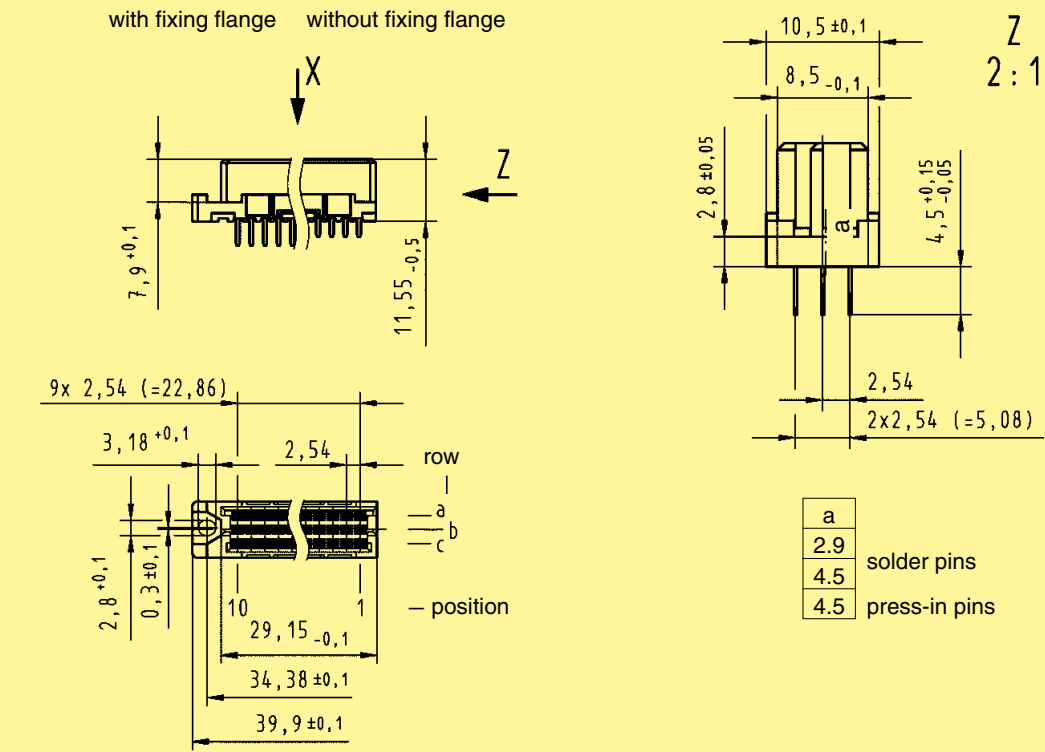

Board drillings
Mounting side

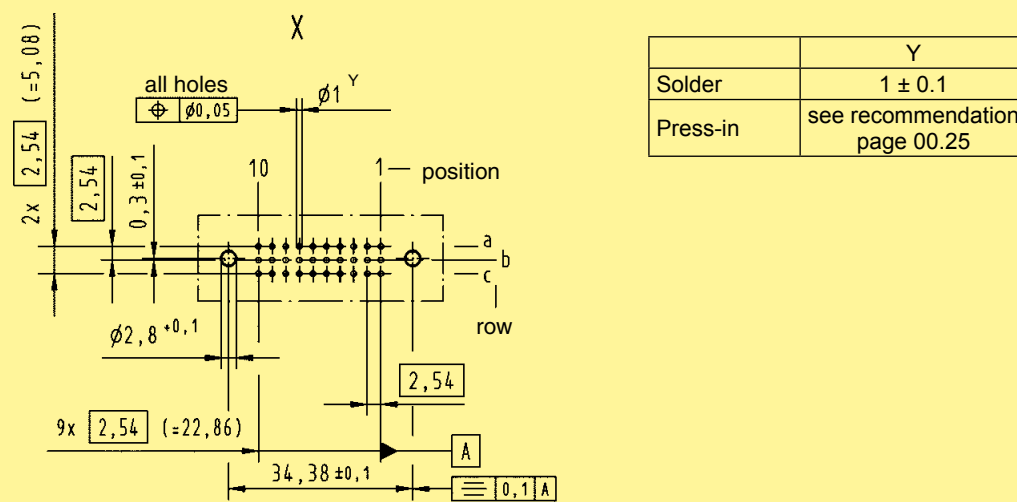

Cross section of solder terminations

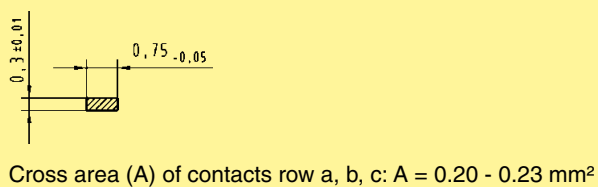

DIN Signal up to 2 A

Application matrix				Board to Backplane			Mezzanine	
				1.	2.	3.	4.	5.
<ul style="list-style-type: none"> • Coax Contacts • High Voltage Contacts • FOC- Contacts 				M male & M female	M male & M flat female	MH 21+ 5 male & MH 21+ 5 female	M invers male & M female	M invers male & M flat female
Connector	Part number							
Male connector type M angled	09 03 1XX X901			○	○			
Female connector type M straight	09 03 2XX 6804			◇			◇	
Female connector type M straight	09 03 2XX 6805			◇			◇	
Female connector type M straight	09 03 2XX 6850			◇			◇	
Female connector type M flat	09 03 2XX 6864				◇			◇
Female connector type M flat	09 03 2XX 6865				◇			◇
Female connector type M flat	09 03 2XX 6830				◇			◇
Male connector type MH 21+5	09 06 X21 6883					○		
Female connector type MH 21+5	09 06 121 6981					◇		
Male connector type M invers	09 73 1XX 6902						○	○
Male connector type M invers	09 73 1XX 6903						○	○
Male connector type M invers	09 73 1XX 6904						○	○
Male connector type M invers	09 73 1XX 6907						○	○
Male connector type M invers	09 73 1XX 6974						○	○
Male connector type M invers	09 73 1XX 6985						○	○
Impedance Termination Part number								
50 Ω	cable	solder/crimp	09 03 000 6160	◆		◆	◆	
50 Ω	cable	solder/crimp	09 03 000 6161	◆		◆	◆	
50 Ω	pcb	solder	09 03 000 6165	◆		◆	◆	
50 Ω	cable	solder	09 03 000 6167	◆		◆	◆	
75 Ω	cable	solder/crimp	09 03 000 6181	◆	◆	◆	◆	
50 Ω	pcb	solder	09 03 000 6182	◆	◆	◆	◆	◆
50 Ω	cable	solder/crimp	09 03 000 6260	●	●	●	●	●
50 Ω	cable	solder/crimp	09 03 000 6261	●	●	●	●	●
50 Ω	pcb	solder	09 03 000 6262	●	●	●	●	●
50 Ω	pcb	solder	09 03 000 6263	●	●	●	●	●
75 Ω	pcb	solder	09 03 000 6269	●	●	●	●	●
50 Ω	cable	solder/crimp	09 03 000 6274	●	●	●	●	●
75 Ω	cable	solder/crimp	09 03 000 6281	●	●	●	●	●
High voltage 1.5 KV								
			09 03 000 6140	●		●	●	
			09 03 000 6240	◆		◆	◆	
FOC ceramic ferrule*								
			20 10 125 4212	●		●	●	
			20 10 125 4222	◆		◆	◆	
FOC for SI-fibre (HCS)*								
			20 10 230 4211	●		●	●	
			20 10 230 4221	◆		◆	◆	
FOC for 1 mm (POF)*								
			20 10 001 4211	●		●	●	
			20 10 001 4221	◆		◆	◆	

● = can be used in ○ male connector

○ = male connector for ● contacts

* details see catalogue Industrial Connectors Han®

◆ = can be used in ◇ female connector

◇ = female connector for ◆ contacts

Application matrix • High Power Contacts					Board to Backplane			Mezzanine	
					1. M male & M female	2. M male & M flat female	3. MH 21+ 5 male & MH 21+ 5 female	4. M invers male & M female	5. M invers male & M flat female
Steckverbinder		Part number							
Male connector type M angled	09 03 1XX X901				○	○			
Female connector type M straight	09 03 2XX 6804				◇			◇	
Female connector type M straight	09 03 2XX 6805				◇			◇	
Female connector type M straight	09 03 2XX 6850				◇			◇	
Female connector type M flat	09 03 2XX 6864					◇			◇
Female connector type M flat	09 03 2XX 6865					◇			◇
Female connector type M flat	09 03 2XX 6830					◇			◇
Male connector type MH 21+5	09 06 X21 6883						○		
Female connector type MH 21+5	09 06 121 6981						◇		
Male connector type M invers	09 73 1XX 6902							○	○
Male connector type M invers	09 73 1XX 6903							○	○
Male connector type M invers	09 73 1XX 6904							○	○
Male connector type M invers	09 73 1XX 6907							○	○
Male connector type M invers	09 73 1XX 6974							○	○
Male connector type M invers	09 73 1XX 6985							○	○
Currency									
Termination	Preleading	Part number							
10 A cable solder	–	09 03 000 6101			●	●	●	●	●
20 A cable solder	–	09 03 000 6102			●	●	●	●	●
40 A cable solder	–	09 03 000 6103			●	●	●	●	●
40 A pcb solder	–	09 03 000 6104			●	●	●	●	●
40 A pcb solder	–	09 03 000 6110			●	●	●	●	●
10 A cable solder	0.8	09 03 000 6111			●	●	●	●	●
10 A cable crimp	–	09 03 000 6113			●	●	●	●	●
20 A cable crimp	–	09 03 000 6114			●	●	●	●	●
40 A cable crimp	–	09 03 000 6115			●	●	●	●	●
20 A cable solder	0.8	09 03 000 6122			●	●	●	●	●
40 A pcb solder	–	09 03 000 6127*			●	●	●	●	●
40 A pcb solder	1.8	09 03 000 6128*			●	●	●	●	●
40 A cable solder	0.8	09 03 000 6133			●	●	●	●	●
40 A pcb solder	0.6	09 03 000 6134			●	●	●	●	●
10 A cable solder	–	09 03 000 6201			◆	◆	◆	◆	◆
20 A cable solder	–	09 03 000 6202			◆	◆	◆	◆	◆
40 A cable solder	–	09 03 000 6203			◆	◆	◆	◆	◆
10 A cable crimp	–	09 03 000 6213			◆	◆	◆	◆	◆
20 A cable crimp	–	09 03 000 6214			◆	◆	◆	◆	◆
40 A cable crimp	–	09 03 000 6215			◆	◆	◆	◆	◆
20 A cable crimp	–	09 03 000 6220*			◆	◆	◆	◆	◆
40 A pcb solder	–	09 03 000 6225			◆	◆	◆	◆	◆
40 A cable screw	–	09 03 000 6245			◆	◆	◆	◆	◆
40 A pcb press-in	–	09 03 000 6250			◆	◆	◆	◆	◆

DIN Signal up to 2 A

● = can be used in ○ male connector
 ○ = male connector for ● contacts
 * see also chapter 04

◆ = can be used in ◇ female connector
 ◇ = female connector for ◆ contacts

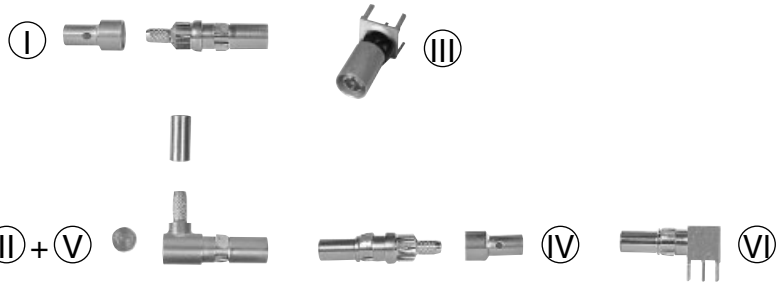

Coaxial contacts

Identification	Part No. Performance level 1	Drawing	Dimensions in mm						
Male coaxial contacts for female connectors I for straight solder and/or crimp termination II for angled solder and/or crimp termination III for straight pcb termination for type M-flat for type M	acc. to DIN 41626 09 03 000 6160 09 03 000 6181 ¹⁾ 09 03 000 6161 09 03 000 6182 09 03 000 6165		<table border="1"> <thead> <tr> <th></th> <th>X</th> </tr> </thead> <tbody> <tr> <td>6165</td> <td>16.05</td> </tr> <tr> <td>6182</td> <td>14.2</td> </tr> </tbody> </table>		X	6165	16.05	6182	14.2
	X								
6165	16.05								
6182	14.2								
Female coaxial contacts for male connectors IV for straight solder and/or crimp termination V for angled solder and/or crimp termination VI angled for pcb termination	09 03 000 6260 09 03 000 6281 ¹⁾ 09 03 000 6274 ²⁾ 09 03 000 6261 09 03 000 6262 09 03 000 6269 ¹⁾ 09 03 000 6263 ²⁾								

Assembly instruction for contacts

I and IV

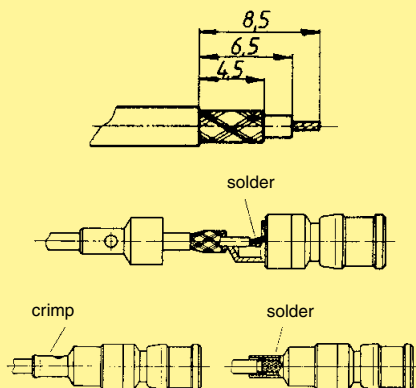

for contacts

II and V

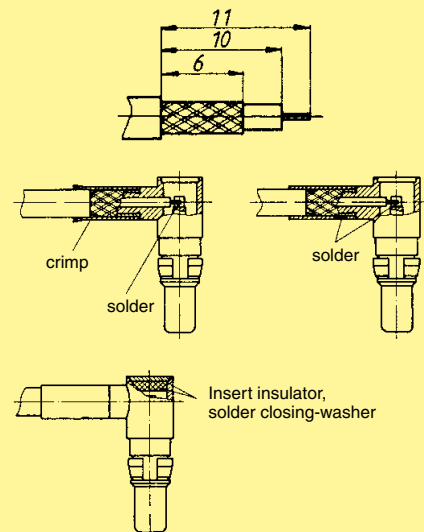

¹⁾ Coaxial contact 75 Ω
²⁾ With knurled area for permanent fixing, not removable
 Fibre optic contacts on request



High voltage contacts

Identification	Part No. Performance level 1	Drawing	Dimensions in mm
I High voltage male contact for male connectors ²⁾ for straight solder termination 2.8 kV	acc. to DIN 41 626 09 03 000 6140		
II High voltage female contact for female connectors ²⁾ for straight solder termination 2.8 kV	09 03 000 6240		
III Crimping tool for coaxial contacts	09 99 000 0194		
Crimping tool for high current contacts	09 99 000 0196		
III Removal tool incl. removal jacket for contact replacement in male and female connectors	09 99 000 0174		
Replacement removal jacket	09 99 000 0243		
IV Removal tool for contact replacement in male connectors	09 99 000 0328		

Electrical characteristics of coaxial contacts and wires

	50 Ω	75 Ω
Impedance	50 Ω	75 Ω
Max. working frequency	0 up to 10 GHz	0 up to 1.5 GHz
Return loss	≥ 20 dB up to 6 GHz	≥ 20 dB
RF-leakage	≥ 80 dB up to 0.5 GHz ≥ 68 dB up to 1.5 GHz	
Test voltage	750 V _{rms}	
Working voltage	250 V _{max.}	
Insulation resistance	≥ 1 GΩ	≥ 200 MΩ
Contacts resistance – Center contact	≤ 10 mΩ	
– Outer contact	≤ 3 mΩ	
Contact current max.	1.5 A	
Admissible power (depends on: frequency, application, return loss, environmental characteristics)	Data on request	

Cable group 2 flexible wires	Impedance	Shell ø	Screening ø	Dielectric ø	Internal wire ø	Hexagonal crimp Spanner width
RG 174 A/U	50 Ω	2.5	2.0	1.5	0.48	3.25
RG 188 A/U	50 Ω	2.6	2.0	1.5	0.54	3.25
RG 316 U	50 Ω	2.5	2.0	1.5	0.54	3.25
RG 179 B/U	75 Ω	2.54	2.0	1.6	0.3	3.25

¹⁾ Contact resistance max. 1.5 mΩ

²⁾ Contact resistance internal wire max. 3 mΩ

DIN 41 612 · Special contacts type M

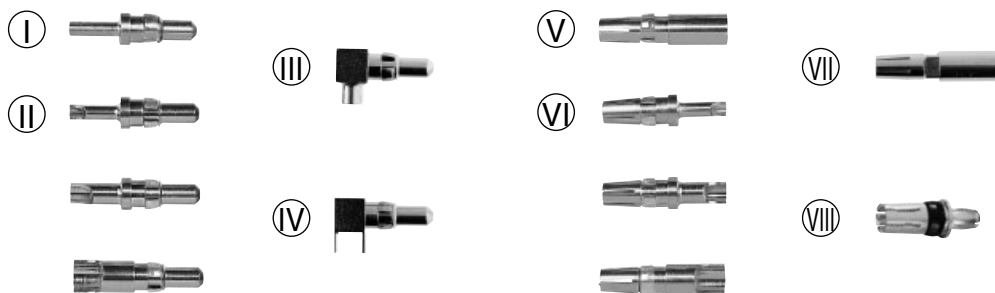

High current contacts

DIN Signal up to 2 A

Identification Part No. Performance level 1 Drawing Dimensions in mm

High current male contacts for male connectors¹⁾

I	for straight crimp termination	10 A	09 03 000 6113
		20 A	09 03 000 6114
		40 A	09 03 000 6115
II	for straight solder termination	10 A	09 03 000 6101
		20 A	09 03 000 6102
		40 A	09 03 000 6103
	Leading contact	10 A	09 03 000 6111
		20 A	09 03 000 6122
III	for angled pcb termination	max. 40 A*	09 03 000 6110
		IV	max. 40 A*
IV	Leading contact	max. 40 A*	09 03 000 6134

* depending on the pcb design

acc. to DIN 41626

	ø A	ø B	wire gauge [mm ²]	AWG
10 A	1.85	2.55	1.5	16
20 A	2.85	3.70	4	12
40 A	4.40	5.60	10	8

	ø
10 A	1.7
20 A	2.8
40 A	4.8

	x	y
... 6104	17.7	6.4
... 6134	18.4	7.0

High current female contacts for female connectors¹⁾

V	for straight crimp termination	10 A	09 03 000 6213
		20 A	09 03 000 6214
		40 A	09 03 000 6215
VI	for straight solder termination	10 A	09 03 000 6201
		20 A	09 03 000 6202
		40 A	09 03 000 6203
VII	for screw fixing on busbar	40 A	09 03 000 6245
VIII	for type M-flat for press-in termination	40 A	09 03 000 6250
		for solder termination	40 A

acc. to DIN 41626

	ø A	ø B	wire gauge [mm ²]	AWG
10 A	1.85	2.55	1.5	16
20 A	2.80	3.70	4	12
40 A	4.40	5.60	10	8

	ø
10 A	1.7
20 A	2.8
40 A	4.8

¹⁾ Contact resistance max. 1.5 mΩ
²⁾ Contact resistance internal wire max. 3 mΩ

Number of contacts

78+2, 60+4, 42+6, 24+8

Male connectors



Identification	Number of contacts	Contact arrangement	Part No.			Performance levels according to IEC 60603-2. Explanation chapter 00		
			3	2	1	3	2	1
Male connector with angled solder pins (without special contacts)*	78 + 2		09 03 178 7901	09 03 178 6901 09 03 178 6901 222 ^{f)} 09 03 378 6901 ^{b)}	09 03 178 2901 09 03 378 2901 ^{b)}			
	60 + 4		09 03 160 7901	09 03 160 6901	09 03 160 2901			
	42 + 6		09 03 142 7901	09 03 142 6901	09 03 142 2901			
	24 + 8		09 03 124 7901	09 03 124 6901 09 03 124 6901 222 ^{f)}	09 03 124 2901			

Dimensions

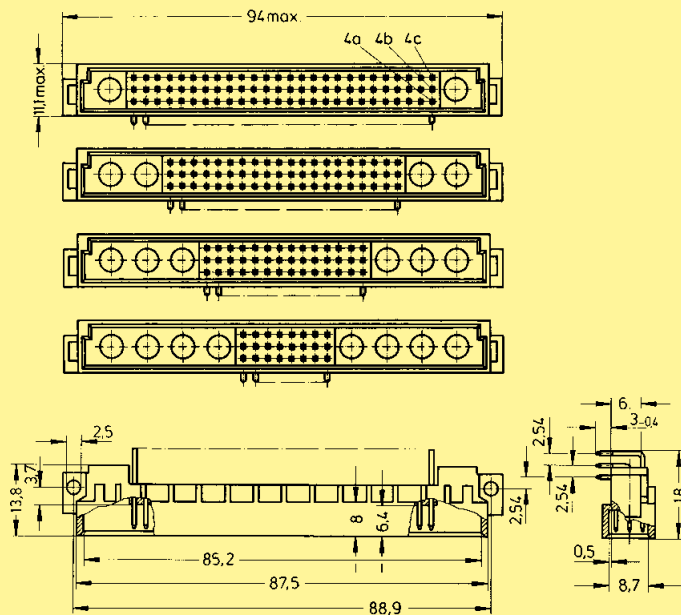

Angled solder pins

Order high current, high voltage, coaxial and fibre optic contacts separately, see pages 01.38 ff

Board drillings

Mounting side

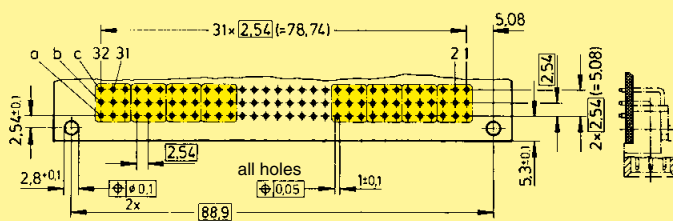

Board drillings depend on type and special contact loading

Dimensions in mm

* Pre-loaded with special contacts on request
^{b)} Connectors with snap-in clips see chapter 00
^{f)} Railway classification NFF 16-101, Smoke index: F1, Flammability class: I2

Number of contacts

**78+2, 60+4,
42+6, 24+8**

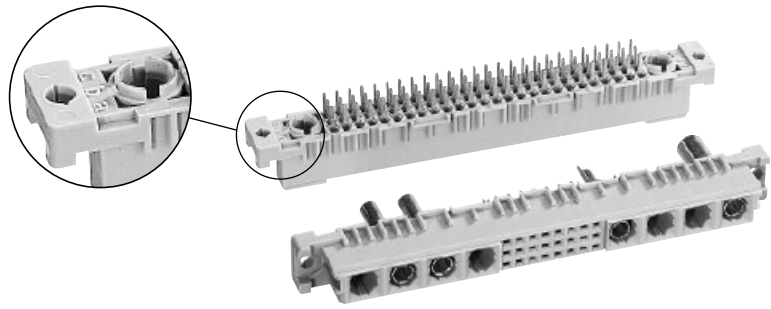

Female connectors

DIN Signal
up to 2 A

Identification	Number of contacts	Contact arrangement	Part No.	Performance levels according to IEC 60 603-2. Explanation chapter 00			
				3	2	1	
Female connector with solder pins 2.9 mm (without special contacts)	78 + 2		Performance level 3 on request	09 03 278 6804	Performance level 1 on request		
	60 + 4			09 03 260 6804			
	42 + 6			09 03 242 6804			
	24 + 8			09 03 224 6804			
Female connector with solder pins 4.5 mm (without special contacts)	78 + 2			09 03 278 6805		Performance level 1 on request	
	60 + 4			09 03 278 6805 222 ¹⁾			
	42 + 6			09 03 260 6805			
	24 + 8			09 03 242 6805			
Female connector with press-in pins 4.5 mm (without special contacts)	78 + 2			09 03 278 6850			Performance level 1 on request
	60 + 4			09 03 260 6850			
	42 + 6			09 03 242 6850			
	24 + 8			09 03 224 6850			

Dimensions

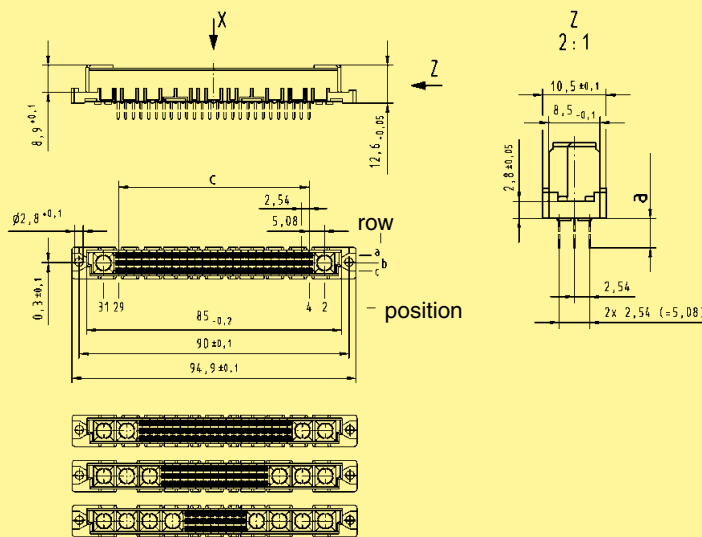

Order high current, high voltage, coaxial and fibre optic contacts separately, see pages 01.38 ff

Board drillings

Mounting side

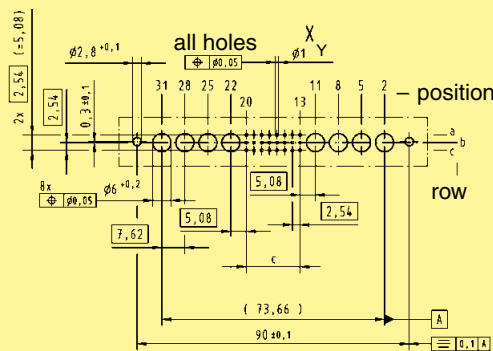

	Y
Solder	1 ± 0.1
Press-in	see recommendation page 00.25

Type	c
78 + 2	25 x 2.54 = 63.5
60 + 4	19 x 2.54 = 48.26
42 + 6	13 x 2.54 = 33.02
24 + 8	7 x 2.54 = 17.78

Dimensions in mm

Other contact arrangements on request

¹⁾ Railway classification NFF 16-101, Smoke index: F1, Flammability class: I2

DIN 41 612 · complementary type M-flat



Number of contacts

78+2, 60+4, 42+6, 24+8

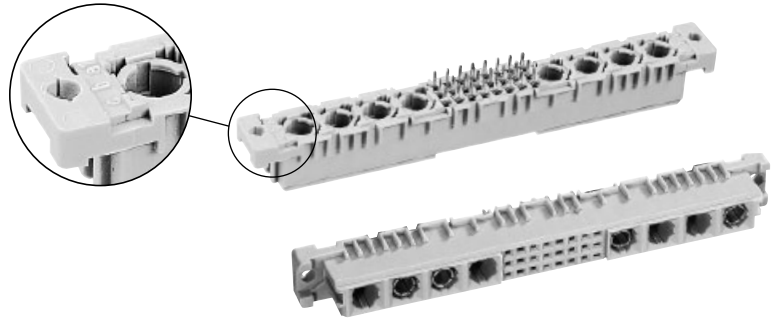

Female connectors

Identification	Number of contacts	Contact arrangement	Part No.	Performance levels according to IEC 60 603-2. Explanation chapter 00		
				3	2	1
Female connector with solder pins 2.9 mm (without special contacts)*	78 + 2		Performance level 3 on request	09 03 278 6864	Performance level 1 on request	
	60 + 4			09 03 260 6864		
	42 + 6			09 03 242 6864		
	24 + 8			09 03 224 6864 09 03 224 6864 222 ^{f)}		
Female connector with solder pins 4.5 mm (without special contacts)*	78 + 2			09 03 278 6865		
	60 + 4			09 03 260 6865		
	42 + 6			09 03 242 6865		
	24 + 8			09 03 224 6865		
Female connector with press-in pins 4.5 mm (without special contacts)*	78 + 2			09 03 278 6830		
	60 + 4			09 03 260 6830		
	42 + 6			09 03 242 6830		
	24 + 8			09 03 224 6830		

DIN Signal up to 2 A

Dimensions

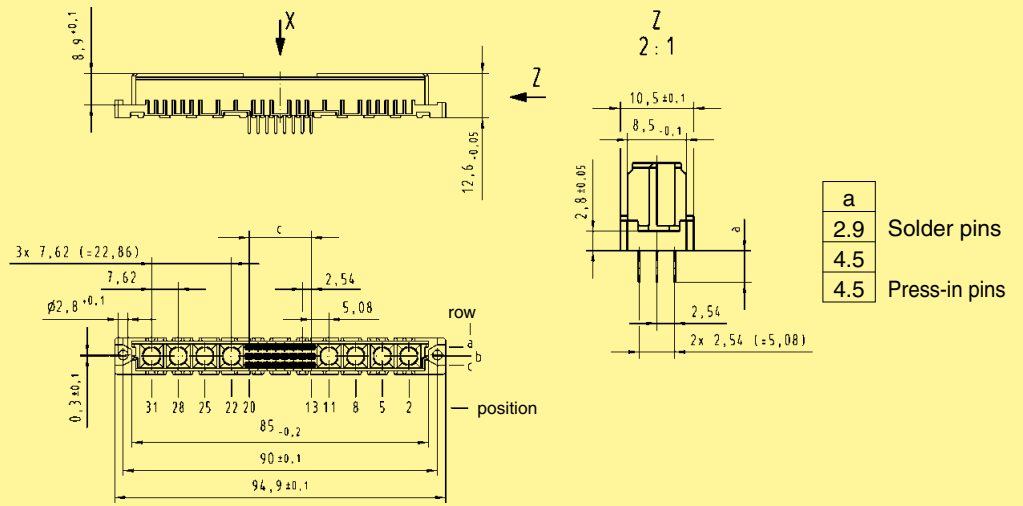

Order high current, high voltage, coaxial and fibre optic contacts separately, see pages 01.38 ff

Board drillings

Mounting side

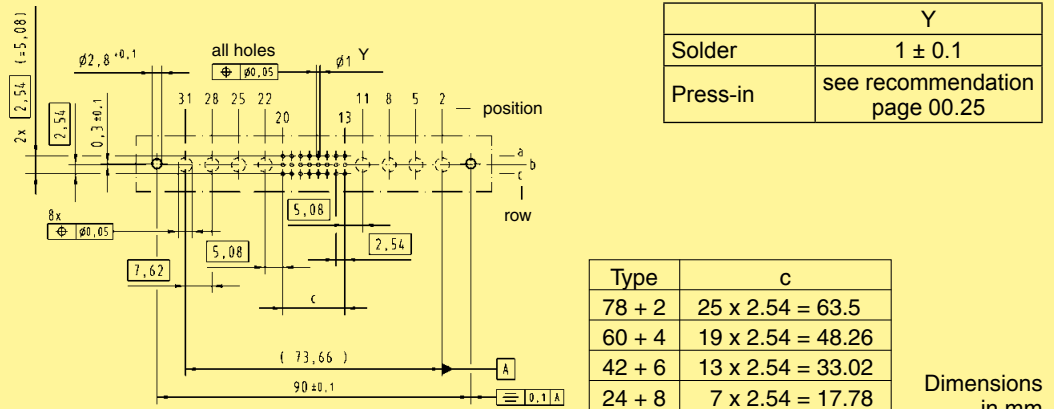

Board drillings depend on type and special contact loading

Dimensions in mm

* Pre-loaded with special contacts on request
^{f)} Railway classification NFF 16-101, Smoke index: F1, Flammability class: I2

Number of contacts

78+2, 60+4, 42+6, 24+8

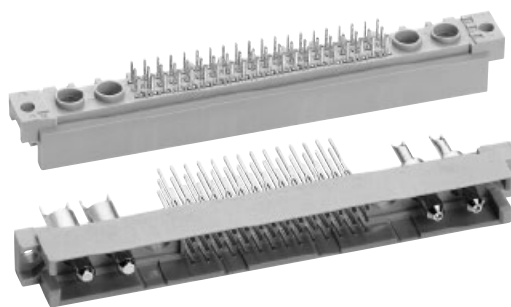

Male connectors

DIN Signal
up to 2 A

Identification Number of contacts Contact arrangement Part No. Performance levels according to IEC 60 603-2. Explanation chapter 00

Identification	Number of contacts	Contact arrangement	Part No.	Performance levels according to IEC 60 603-2. Explanation chapter 00	
				3	2
					1
Male connector with solder pins 2.5 mm	78 + 2		Performance level 3 on request	09 73 178 6902	Performance level 1 on request
	60 + 4			09 73 160 6902	
	42 + 6			09 73 142 6902	
	24 + 8			09 73 124 6902	
Male connector with solder pins 4.0 mm	78 + 2			09 73 178 6903	
	60 + 4			09 73 160 6903	
	42 + 6			09 73 142 6903	
	24 + 8			09 73 124 6903	
Male connector with wrap posts 13 mm	78 + 2			09 73 178 6907	
	60 + 4			09 73 160 6907	
	42 + 6			09 73 142 6907	
	24 + 8			09 73 124 6907	
Male connector with press-in pins 5.5 mm	78 + 2			09 73 178 6904	
	60 + 4			09 73 160 6904	
	42 + 6			09 73 142 6904	
	24 + 8			09 73 124 6904	
Male connector with press-in pins 13 mm	78 + 2		09 73 178 6985 09 73 178 6974●		
	60 + 4		09 73 160 6985 09 73 160 6974●		
	42 + 6		09 73 142 6985 09 73 142 6974●		
	24 + 8		09 73 124 6985		

Male connectors with 17 mm wrap posts on request
 ● Wrap posts for interfacing selectively gold plated (performance level 3)
 Other contact arrangements on request

Number of contacts

78+2, 60+4,
42+6, 24+8

Male connectors

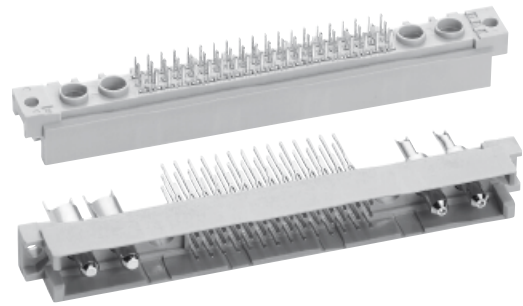

Identification

Drawing

Dimensions in mm

Dimensions

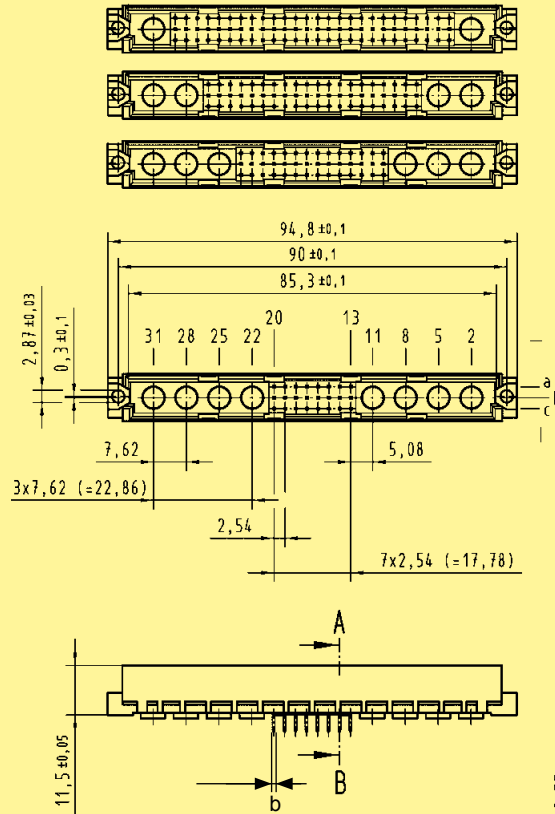

a	b	
2.5	ø 0.7	Solder pins
4.0		
13	□ 0.6	Wrap posts
5.5	–	Press-in pins
13	–	

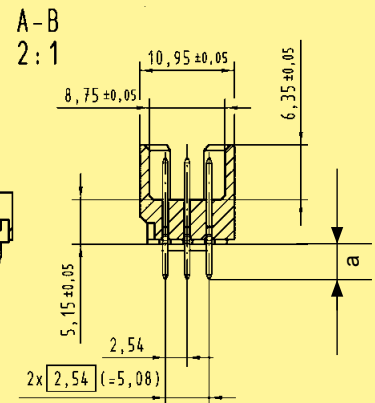

Order high current, high voltage, coaxial and fibre optic contacts separately, see pages 01.38 ff

Board drillings

Mounting side

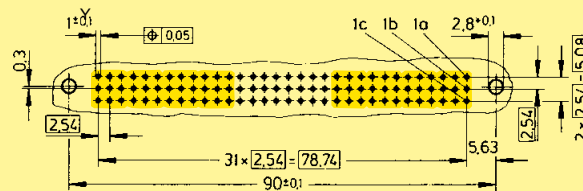

	Y
Solder	1 ± 0.1
Press-in	see recommendation page 00.25

Board drillings depend on type and special contact loading

Number of contacts

96, 64

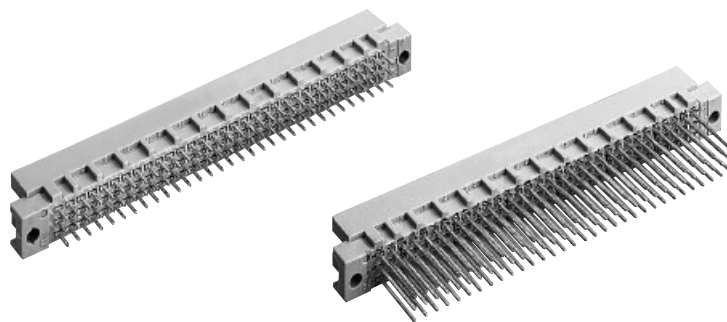

Male connectors

DIN Signal up to 2 A

Identification	Number of contacts	Contact arrangement	Part No.	Performance levels according to IEC 60 603-2. Explanation chapter 00		
				3	2	1
Male connector with solder pins 2.5 mm SMC	96		09 73 196 7902	09 73 196 6902 09 73 396 6902 ^{b)} 09 73 696 6902 ^{c)}	09 73 196 2902	
	96			09 73 196 6519 ^{d)}		
	64		09 73 164 7902	09 73 164 6902 09 73 364 6902 ^{b)}	09 73 164 2902 09 73 364 2902 ^{b)}	
Male connector with solder pins 4.0 mm SMC	96		09 73 196 7903	09 73 196 6903 09 73 196 6903 222 ^{f)} 09 73 396 6903 ^{b)} 09 73 196 6953	09 73 196 2903	
	94 + 2 [▲]			09 73 196 6520 ^{d)}		
	64		09 73 164 7903	09 73 164 6903 09 73 364 6903 ^{b)}	09 73 164 2903	
Male connector with solder pins 13 mm SMC	96			09 73 196 6577	09 73 196 2577	
	96			09 73 196 6521 ^{d)}		
	64			09 73 164 6577		
Male connector with wrap posts ¹⁾ 13 mm	96		09 73 196 7907	09 73 196 6907 09 73 696 6947 ^{●c)}	09 73 196 2907	
	64		09 73 164 7907	09 73 164 6907 09 73 164 6947 [●] 09 73 664 6947 ^{●c)}	09 73 164 2907	
Male connector with press-in pins 5.0 mm	96		09 73 196 7904	09 73 196 6904 09 73 696 6904 ^{c)} 09 73 196 6954	performance level 1 or special gold plating on request	
	94 + 2 [▲]					
Male connector with press-in pins 13 mm	64		09 73 164 7904	09 73 164 6904		
	96		09 73 196 7974 [●]	09 73 196 6985 09 73 196 6974 [●] 09 73 196 6995		
Male connector with press-in pins 13 mm	94 + 2 [▲]			09 73 164 6985 09 73 164 6974 [●]		
	64					

▲ Male connectors with 2 leading contacts [(0.8 mm) pos. a1 and a32]
 ● Wrap posts for interfacing selectively gold plated (performance level 3)
 Other contact arrangements as well with lagging pins on request
^{f)} Railway classification NFF 16-101, Smoke index: F1, Flammability class: I2

¹⁾ To be used only for wire wrap termination
^{b)} Connectors with snap-in clips see chapter 00
^{c)} Connectors with coding see chapter 00
^{d)} CTI > 400

Number of contacts

96, 64, 32

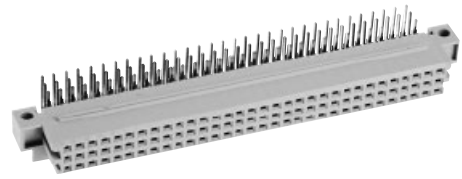

Female connectors

Identification	Number of contacts	Contact arrangement	Part No. Performance levels according to IEC 60603-2. Explanation chapter 00		
			3	2	1
Female connector with angled solder pins	96		09 73 296 7801	09 73 296 6801	09 73 296 2801
			09 73 496 7801 ^{b)}	09 73 296 6801 222 ^{f)} 09 73 496 6801 ^{b)} 09 73 796 6801 ^{c)}	
	96			09 73 296 6804 ^{d)} 09 73 496 6804 ^{b)d)}	09 73 296 2804 ^{d)} 09 73 496 2804 ^{b)d)}
	64		09 73 264 7801 09 73 464 7801 ^{b)}	09 73 264 6801 09 73 464 6801 ^{b)}	09 73 264 2801
				09 73 264 6804 ^{d)} 09 73 464 6804 ^{b)d)}	09 73 264 2804 ^{d)} 09 73 464 2804 ^{b)d)}
32		09 73 232 7801	09 73 232 6801	09 73 232 2801	
		09 73 232 7811	09 73 232 6811	09 73 232 2811	

DIN Signal up to 2 A

Dimensions

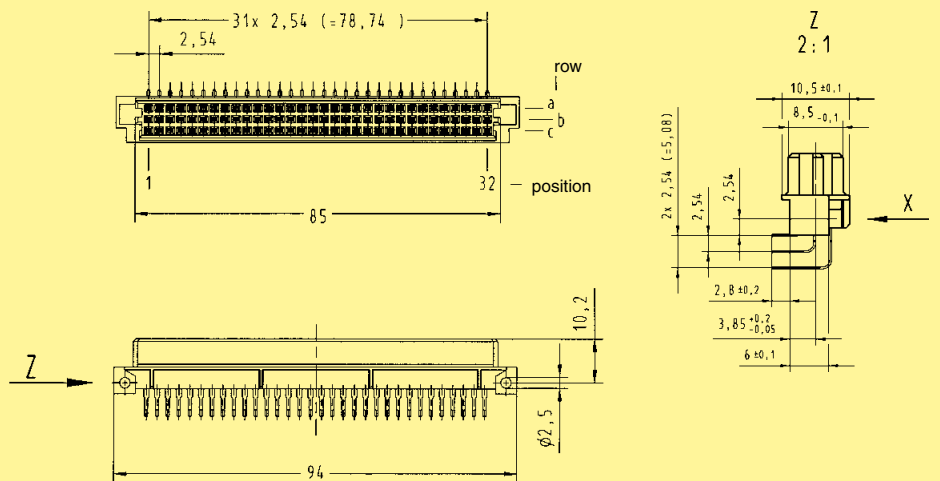

Board drillings
Mounting side

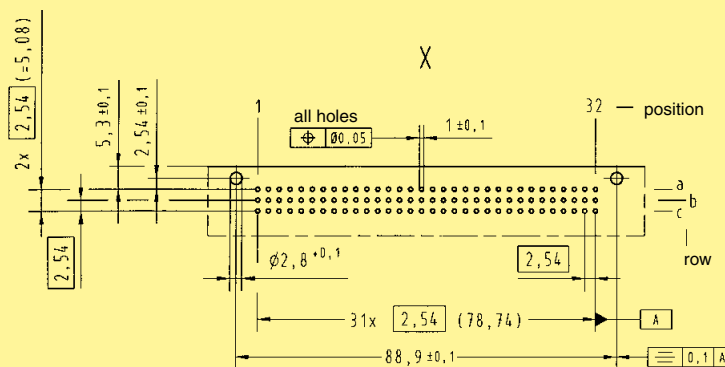

Cross section of solder terminations

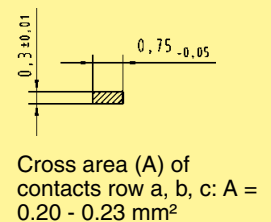

Dimensions in mm

Other contact arrangements on request
^{b)} Connectors with snap-in clips see chapter 00
^{c)} Connectors with coding see chapter 00

^{d)} CTI > 400
^{f)} Railway classification NFF 16-101, Smoke index: F1, Flammability class: I2

DIN 41 612 · complementary to type R (HE 11)



Number of contacts

96, 64

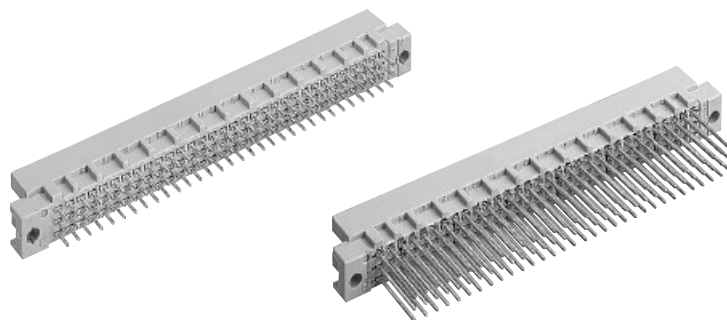

Male connectors

DIN Signal up to 2 A

Identification Number of contacts Contact arrangement Part No. Performance levels according to IEC 60 603-2. Explanation chapter 00

Identification	Number of contacts	Contact arrangement	Part No.	Performance levels according to IEC 60 603-2. Explanation chapter 00		
				3	2 1	
Male connector with solder pins 2.5 mm	96		Performance level 3 on request	Performance level 3 on request	09 79 196 6902	
Male connector with solder pins 4.0 mm	96				09 79 196 6903 09 79 396 6903 ^{b)}	Performance level 1 on request
	64				09 79 164 6903 09 79 364 6903 ^{b)}	
Male connector with wrap posts ¹⁾ 13 mm	96		09 79 196 6907			
	64		09 79 164 6907			

Dimensions

a	b	Solder pins
2.5	∅ 0.7	
4		

a	b	Wrap posts
13	∅ 0.6	

Panel cut out

Board drillings
Mounting side

Contact arrangement
View from termination side

96 64 32

Dimensions in mm

01
50

Other contact arrangements on request

 = deviating dimensions from standard male connectors (see page 01.46f)

^{b)} Connectors with snap-in clips see chapter 00

¹⁾ To be used only for wire wrap termination

Number of contacts

96, 64

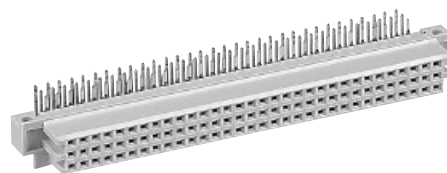

Female connectors

DIN Signal
up to 2 A

Identification	Number of contacts	Contact arrangement	Part No. Performance levels according to IEC 60603-2. Explanation chapter 00		
			3	2	1
Female connector with angled solder pins	96		09 79 296 7801	09 79 296 6801 09 79 496 6801 ^{b)}	Performance level 1 on request
	64		09 79 264 7801	09 79 264 6801 09 79 464 6801 ^{b)}	

Dimensions

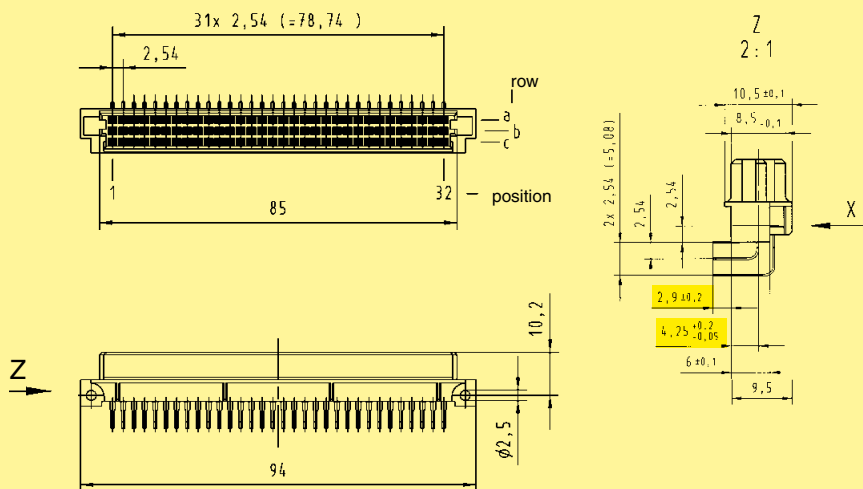

Board drillings

Mounting side

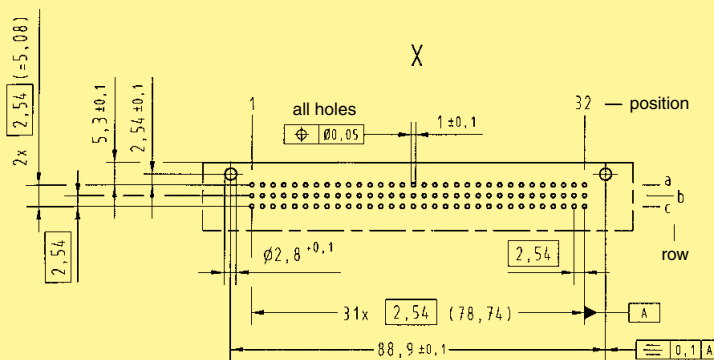

Dimensions in mm

Other contact arrangements on request

^{b)} Connectors with snap-in clips see chapter 00

= deviating dimensions from standard female connectors (see page 01.49)

Number of contacts

64

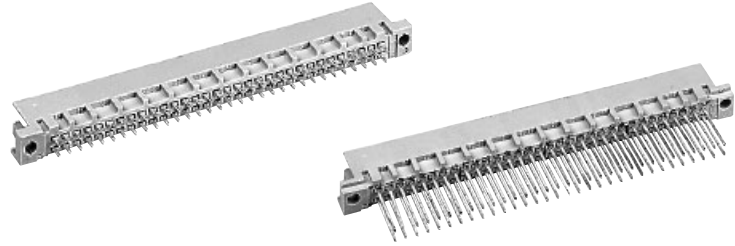

Male connectors

Identification	Number of contacts	Contact arrangement	Part No.	Performance levels according to IEC 60 603-2. Explanation chapter 00
			3	2 1
Male connector with solder pins 2.5 mm	64		09 72 164 7902	09 72 164 6902 09 72 364 6902 ^{b)}
	4.0 mm		09 72 164 7903	09 72 164 6903
	13 mm			09 72 164 6577
Male connector with wrap posts ¹⁾	13 mm		09 72 164 7907	09 72 164 6907
	17 mm			09 72 164 6909
Male connector with press-in pins	64			09 72 164 6904 09 72 164 6904 222 ^{f)} 09 72 164 6954
	62 + 2 [▲]			
	13 mm			09 72 164 6985 09 72 164 6974* 09 72 164 6995

Performance level 1 on request

Dimensions

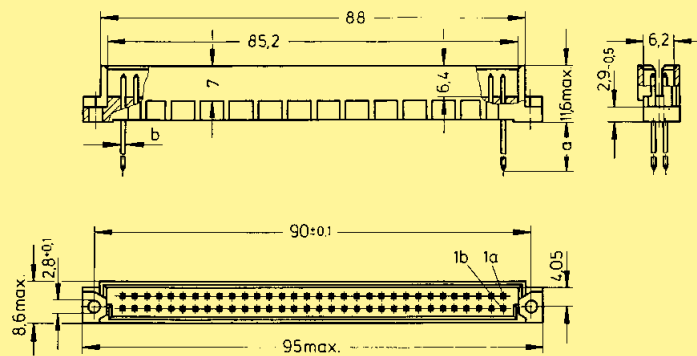

a	b
2.5	∅ 0.7
4	∅ 0.6
13	∅ 0.6
17	∅ 0.6
5	-
13	-

Solder pins
Wrap posts
Press-in pins

Panel cut out

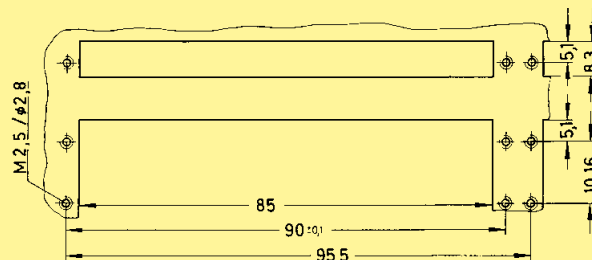

Board drillings

Mounting side

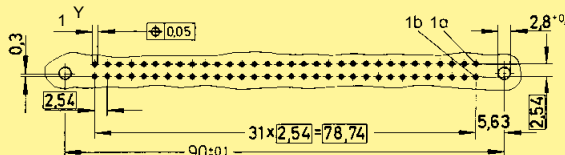

	Y
Solder	1 ± 0.1
Press-in	see recommendation page 00.25

Dimensions in mm

Other contact arrangements as well with lagging/leading pins on request
[▲] Male connectors with 2 leading contacts (0.8 mm) pos. a1 and a32/a16
^{*} Wrap posts for interfacing selectively gold plated (performance level 3)

¹⁾ To be used only for wire wrap termination
^{b)} Connectors with snap-in clips see chapter 00
^{f)} Railway classification NFF 16-101, Smoke index: F1, Flammability class: I2

Number of contacts

32

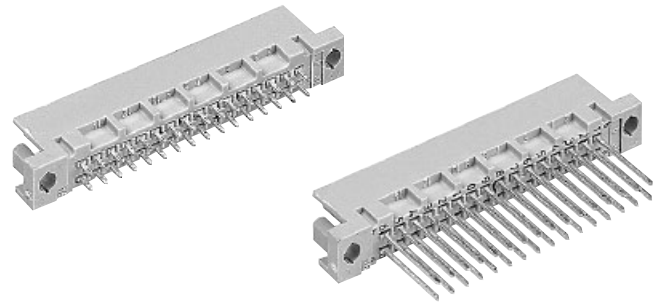

Male connectors

Identification	Number of contacts	Contact arrangement	Part No.	Performance levels according to IEC 60603-2. Explanation chapter 00
			3	2
Male connector with solder pins 2.5 mm	32		09 27 132 7902 09 27 332 7902	09 27 132 6902
	4.0 mm		09 27 132 7903	09 27 132 6903 09 27 132 6903 222 ^{f)}
	13 mm			09 27 132 6577
Male connector with wrap posts ¹⁾ 13 mm	32		09 27 132 7907	09 27 132 6907
Male connector with press-in pins 5.0 mm	32 30 + 2 [▲]			09 27 132 6904 09 27 132 6954

Dimensions

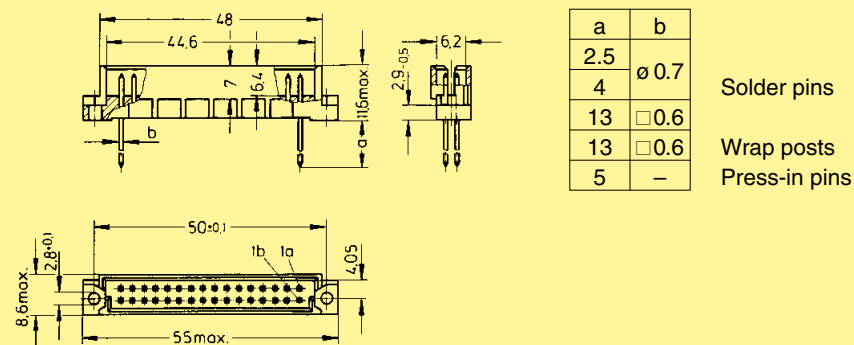

Panel cut out

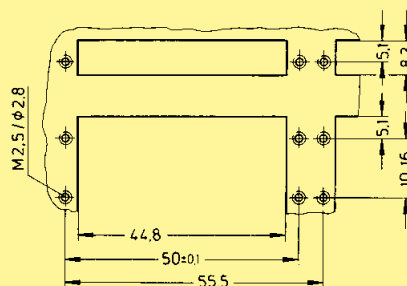

Board drillings

Mounting side

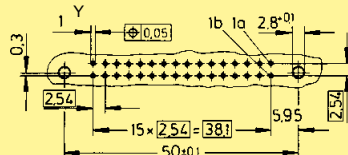

	Y
Solder	1 ± 0.1
Press-in	see recommendation page 00.25

Dimensions in mm

DIN Signal up to 2 A

Other contact arrangements as well with lagging/leading pins on request
 ▲ Male connectors with 2 leading contacts (0.8 mm) pos. a1 and a32/a16
¹⁾ To be used only for wire wrap termination
^{f)} Railway classification NFF 16-101, Smoke index: F1, Flammability class: I2

DIN 41 612 · complementary type 2R



Number of contacts

48, 32

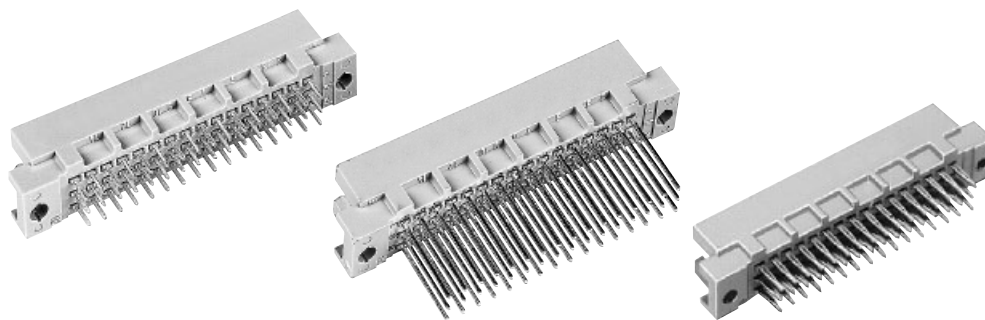

Male connectors

DIN Signal up to 2 A

Identification Number of contacts Contact arrangement Part No. Performance levels according to IEC 60 603-2. Explanation chapter 00

Identification	Number of contacts	Contact arrangement	Part No.	3	2	1
Male connector with solder pins 2.5 mm	48		09 28 148 7902 09 28 348 7902 ^{b)}		09 28 148 6902 09 28 348 6902 ^{b)}	09 28 148 2902
		SMC				
	32		09 28 132 7902		09 28 132 6902	09 28 132 2902
		SMC				
Male connector with solder pins 4.0 mm	48		09 28 148 7903		09 28 148 6903 09 28 148 6903 222 ^{f)} 09 28 348 6903 ^{b)}	09 28 148 2903
		SMC				
	32		09 28 132 7903		09 28 132 6903	09 28 132 2903
		SMC				
Male connector with solder pins 13 mm	48				09 28 148 6577	
	SMC	48			09 28 148 6521 ^{d)}	
Male connector with wrap posts ¹⁾ 13 mm	48		09 28 148 7907		09 28 148 6907	09 28 148 2907
	32		09 28 132 7907		09 28 132 6907	09 28 132 2907
Male connector with press-in pins 5.0 mm	48		09 28 148 7904		09 28 148 6904 09 28 148 6904 222 ^{f)}	
	32					
Male connector with press-in pins 13 mm	48		09 28 148 7985		09 28 148 6985 09 28 148 6974 [•]	
	32					

01
54

• Wrap posts for interfacing selectively gold plated (performance level 3)
^{b)} Connectors with snap-in clips see chapter 00
¹⁾ To be used only for wire wrap termination

^{d)} CTI > 400
^{f)} Railway classification NFF 16-101, Smoke index: F1, Flammability class: I2

DIN 41 612 · complementary type 2R



Number of contacts

48, 32

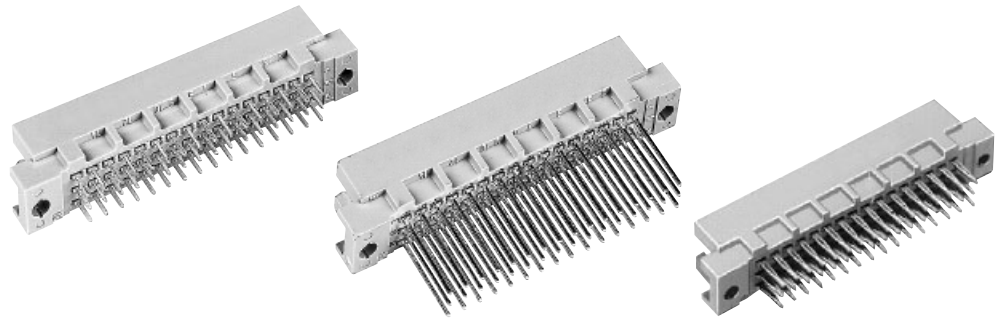

Male connectors

Identification

Drawing

Dimensions in mm

Dimensions

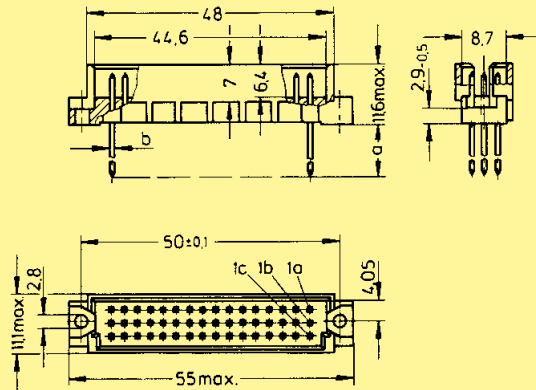

a	b
2.5	∅ 0.7
4	
13	□ 0.6
13	□ 0.6
5	—
13	—

Solder pins

Wrap posts

Press-in pins

Panel cut out

Board drillings
Mounting side

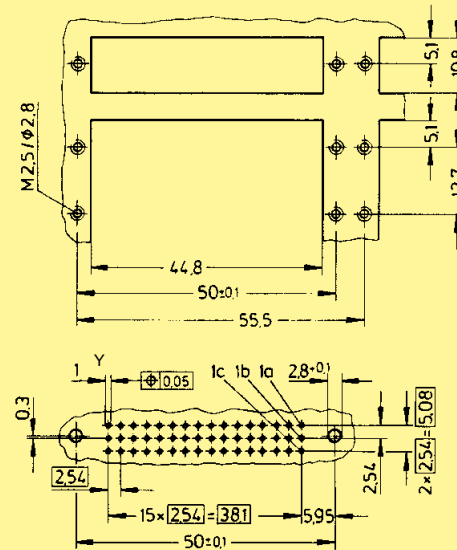

Contact arrangement
View from termination side

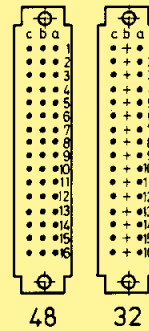

	Y
Solder	1 ± 0.1
Press-in	see recommendation page 00.25

Cross section of solder terminations

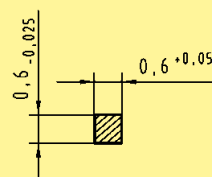

Cross area (A) of contacts row a, b, c: A = 0.35 - 0.39 mm²

DIN Signal
up to 2 A

DIN 41 612 · Type Q – complementary types 2Q, 2R



Number of contacts

64, 48, 32

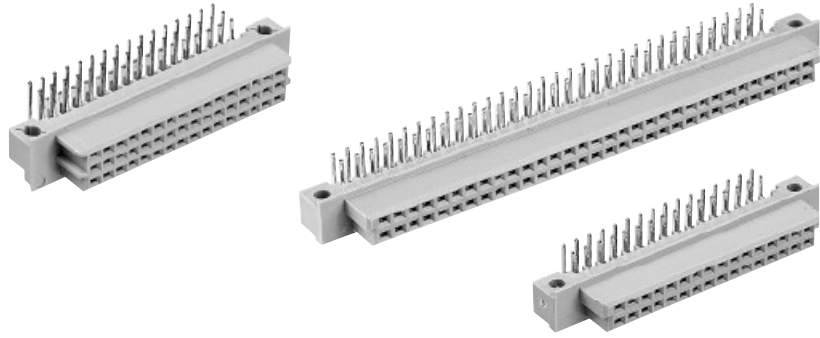

Female connectors

DIN Signal up to 2 A

Identification Number of contacts Contact arrangement Performance level 2 according to IEC 60 603-2. Explanation chapter 00 Part No.

Female connector with angled solder pins

Type Q

64

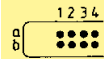

09 72 264 6801
09 72 464 6801^{b)}

Type 2Q

32

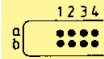

09 27 232 6801
09 27 432 6801^{b)}

Type 2R

48

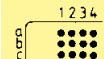

09 28 248 6801
09 28 448 6801^{b)}

Dimensions

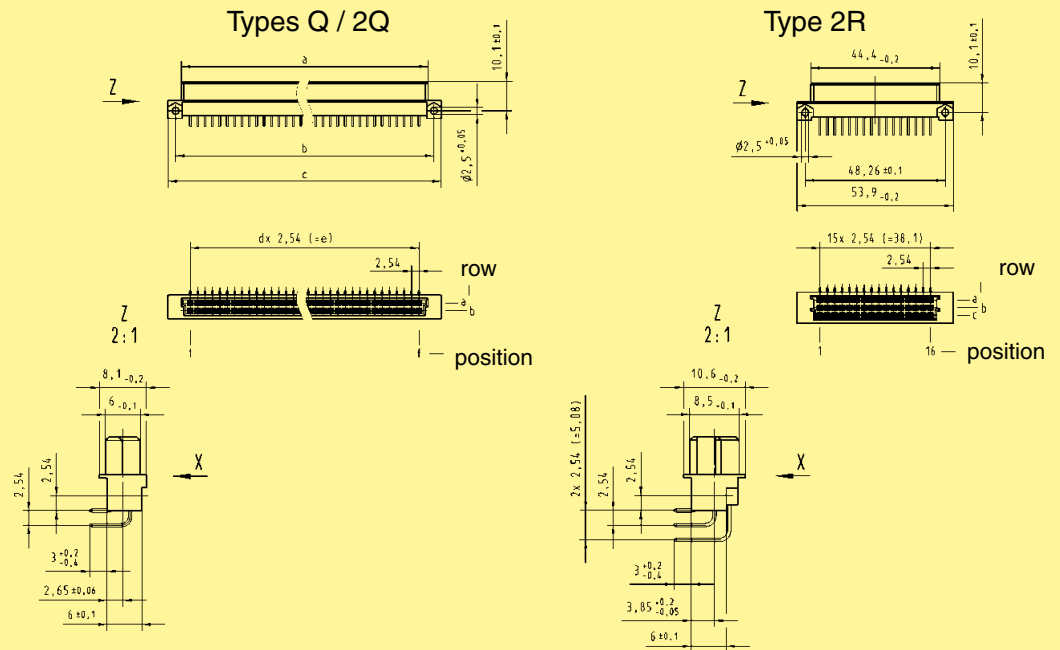

Type	a	b	c	d	e	f
Q	85.0 ^{-0.2}	88.90 ^{±0.1}	94.0 ^{-0.2}	31	78.74	32
2Q	44.4 ^{-0.2}	48.26 ^{±0.1}	53.9 ^{-0.2}	15	38.10	16

Board drillings

Mounting side

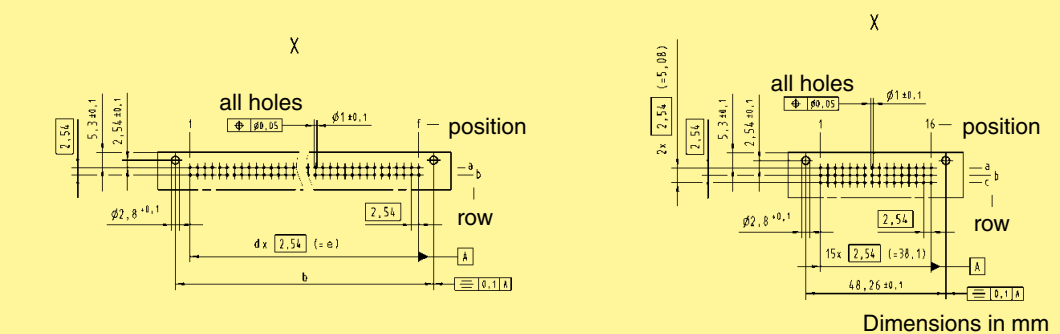

Dimensions in mm

Number of contacts

96, 48

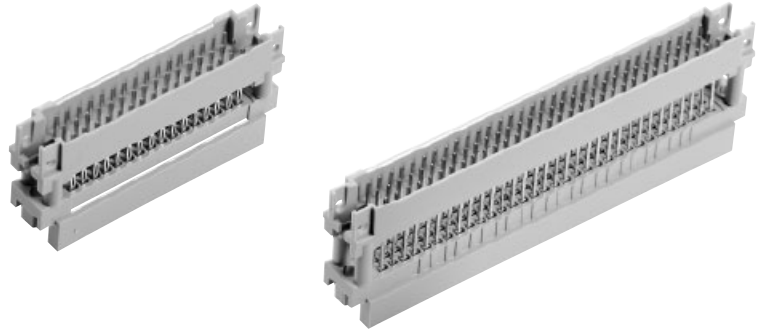

Mezzanine Adapter

Identification	Number of contacts	Contact arrangement	Part No.	Performance levels according to IEC 60 603-2.		
				3	2	1
Male connector type R with pin shroud for pcb distance 39.5 mm	96		Performance level 3 on request			09 73 196 5531
Male connector type 2R with pin shroud for pcb distance 39.5 mm 35 mm	48				09 28 148 6532	09 28 148 5531

DIN Signal up to 2 A

Dimensions

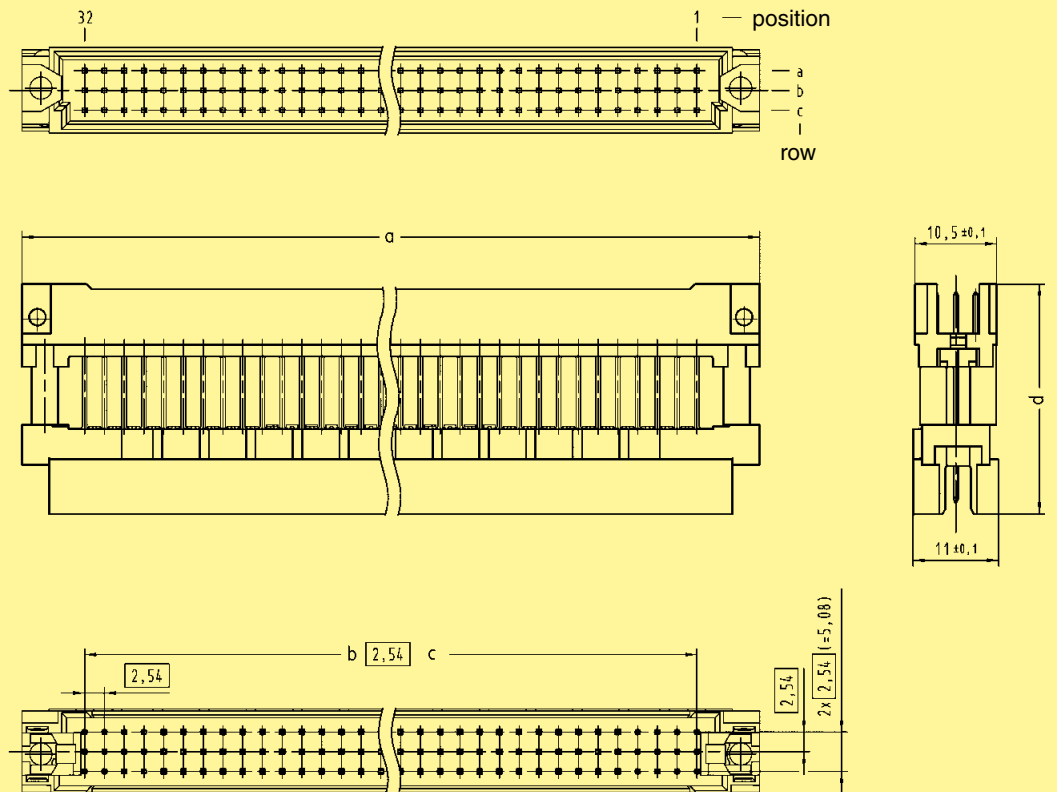

	a	b	c	d
09 73 148 5531	94.9 ± 0.1	31	78.74	29.6 ± 0.3
09 28 148 5531	54.9 ± 0.1	15	38.1	29.6 ± 0.3
09 28 148 6532	54.9 ± 0.1	15	38.1	26.15 ± 0.3

Dimensions in mm

Pin shroud



Number of contacts

96, 48

Pin shrouds
for types C, 2C, R, 2R

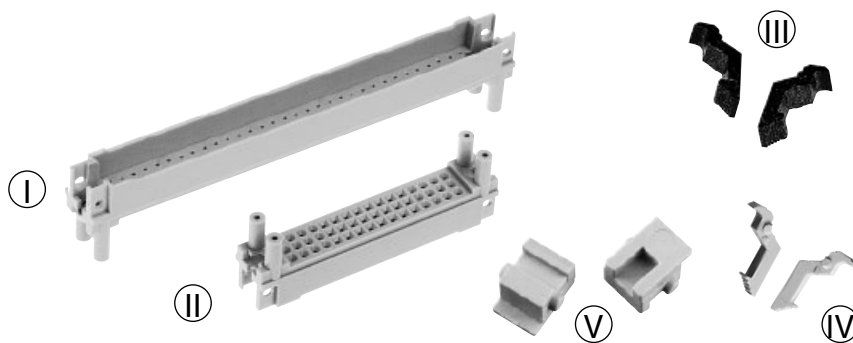

DIN Signal
up to 2 A

Identification	Termination length ± 0.3	pcb-thickness ± 0.4	Dimension a ± 0.1	Part No. – Pin shrouds with		
				press-in fixing ¹⁾	screw fixing	
Pin shrouds for female connectors type C, R I	13.0/ 13.2	1.6	6.7	09 03 000 9956	09 03 000 9966	
		2.4	5.9	09 03 000 9957	09 03 000 9967	
		3.2	5.1	09 03 000 9958	09 03 000 9968	
		4.0	4.3	09 03 000 9959	09 03 000 9969	
		4.0	4.3	09 03 000 9959	09 03 000 9969	
	17.0	1.6	9.9	09 03 000 9952	09 03 000 9962	
		2.4	9.1	09 03 000 9953	09 03 000 9963	
		3.2	8.3	09 03 000 9954	09 03 000 9964	
		4.0	7.5	09 03 000 9955	09 03 000 9965	
		4.8	6.7	09 03 000 9956	09 03 000 9966	
		5.6	5.9	09 03 000 9957	09 03 000 9967	
		6.4	5.1	09 03 000 9958	09 03 000 9968	
	20.0	3.2	11.75	09 03 000 9950	09 03 000 9960	
		4.0	10.7	09 03 000 9951	09 03 000 9961	
		4.8	9.9	09 03 000 9952	09 03 000 9962	
		5.6	9.1	09 03 000 9953	09 03 000 9963	
		6.4	8.3	09 03 000 9954	09 03 000 9964	
		7.2	7.5	09 03 000 9955	09 03 000 9965	
	Pin shrouds for female connectors type 2C, 2R II	13.0/ 13.2	1.6	6.7	09 23 000 9956	09 23 000 9966
			2.4	5.9	09 23 000 9957	09 23 000 9967
			3.2	5.1	09 23 000 9958	09 23 000 9968
4.0			4.3	09 23 000 9959	09 23 000 9969	
4.0			4.3	09 23 000 9959	09 23 000 9969	
17.0		1.6	9.9	09 23 000 9952	09 23 000 9962	
		2.4	9.1	09 23 000 9953	09 23 000 9963	
		3.2	8.3	09 23 000 9954	09 23 000 9964	
		4.0	7.5	09 23 000 9955	09 23 000 9965	
		4.8	6.7	09 23 000 9956	09 23 000 9966	
		5.6	5.9	09 23 000 9957	09 23 000 9967	
		6.4	5.1	09 23 000 9958	09 23 000 9968	
20.0		3.2	11.75	09 23 000 9950	09 23 000 9960	
		4.0	10.7	09 23 000 9951	09 23 000 9961	
		4.8	9.9	09 23 000 9952	09 23 000 9962	
		5.6	9.1	09 23 000 9953	09 23 000 9963	
		6.4	8.3	09 23 000 9954	09 23 000 9964	
		7.2	7.5	09 23 000 9955	09 23 000 9965	

Identification	Part No.
Locking lever for female connectors type C, 2C* III	09 03 000 9914
Locking lever for female connectors type R, 2R* IV	09 03 000 9913
Fixing bracket for shell housing C* V	09 03 000 9921

01
58

* order 2 pieces per connector

¹⁾ Tooling see chapter 30

Pin shroud



Number of contacts

96, 48

Pin shrouds
for types C, 2C, R, 2R

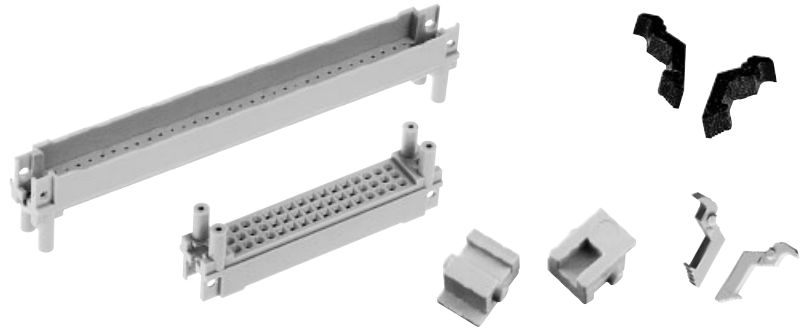

Identification

Drawing

Dimensions in mm

Pin shrouds
for female connectors
type C, R

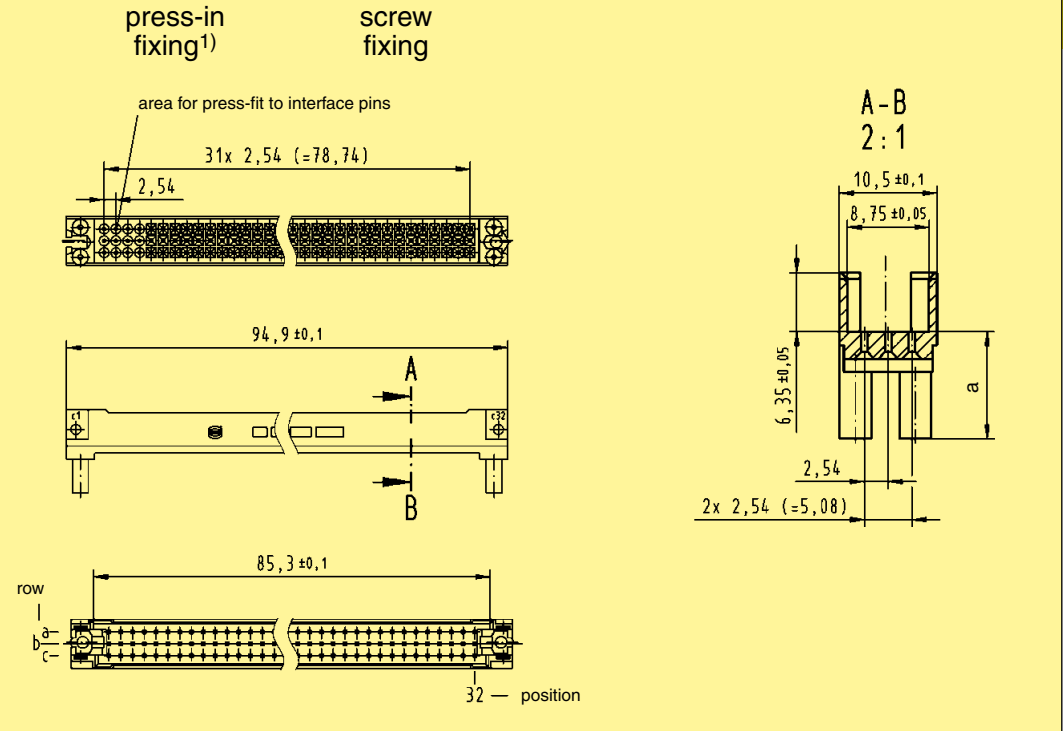

Pin shrouds
for female connectors
type 2C, 2R

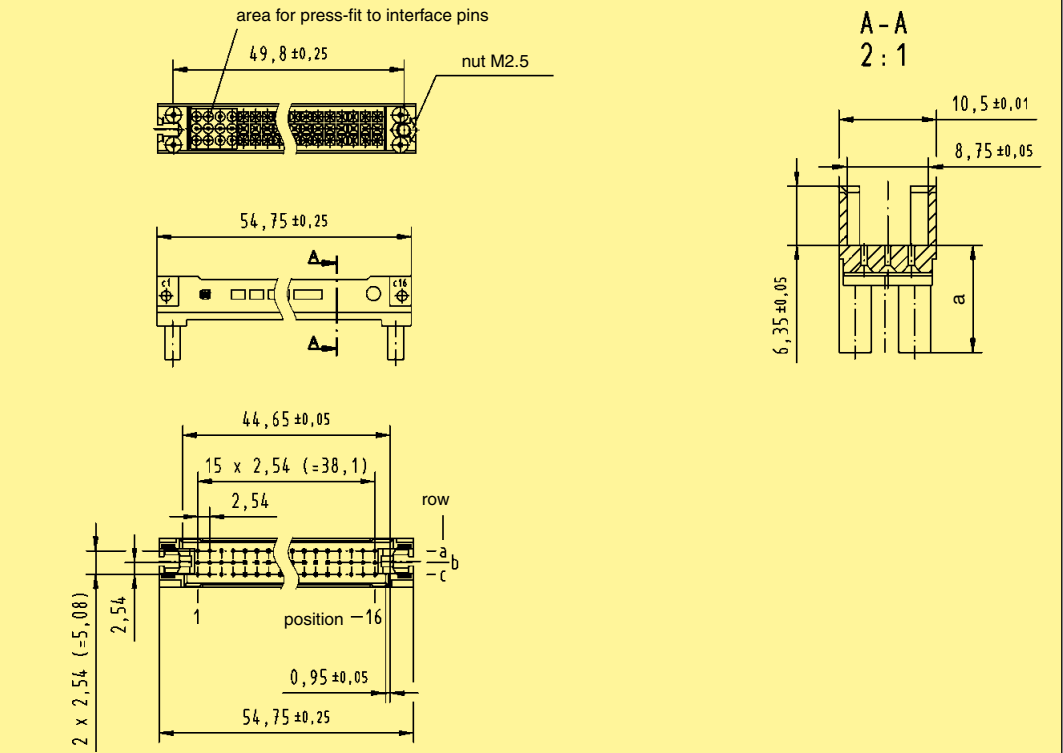

¹⁾ Tooling see chapter 30

DIN Signal
up to 2 A

Application 1

Female connector
09 03 296 6861



Backplane

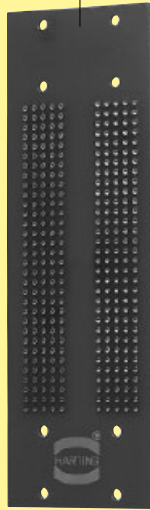

Pin shroud
09 03 000 9957



Locking lever
09 03 000 9914

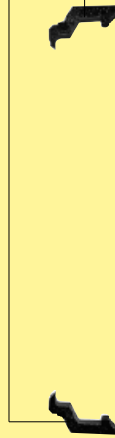

Female connector
09 03 264 6828

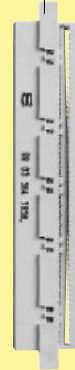

Female connector
09 03 096 3214



Application 2

Female connector
09 03 296 6862



Backplane

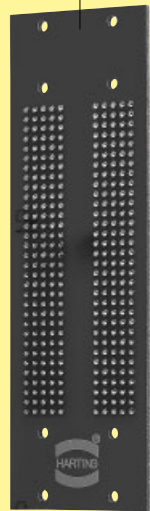

Pin shroud
09 03 000 9953



Locking lever
09 03 000 9913

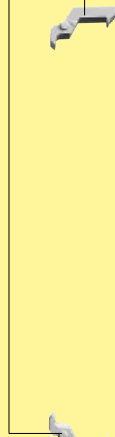

Female connector
09 73 296 6801



Daughtercard

Application 3

Female connector
09 03 296 6861

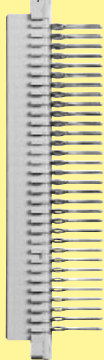

Backplane

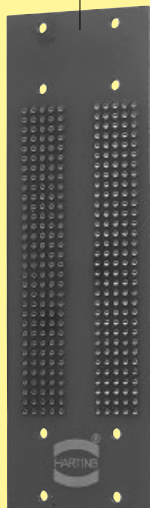

Pin shroud
09 03 000 9957



Fixing brackets
09 03 000 9921

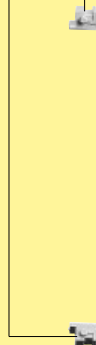

Female connector
09 03 096 3214



Locking levers
left 09 02 000 9902
right 09 02 000 9903

Shell housing C
09 03 096 0501



DIN Signal
up to 2 A

Application 4

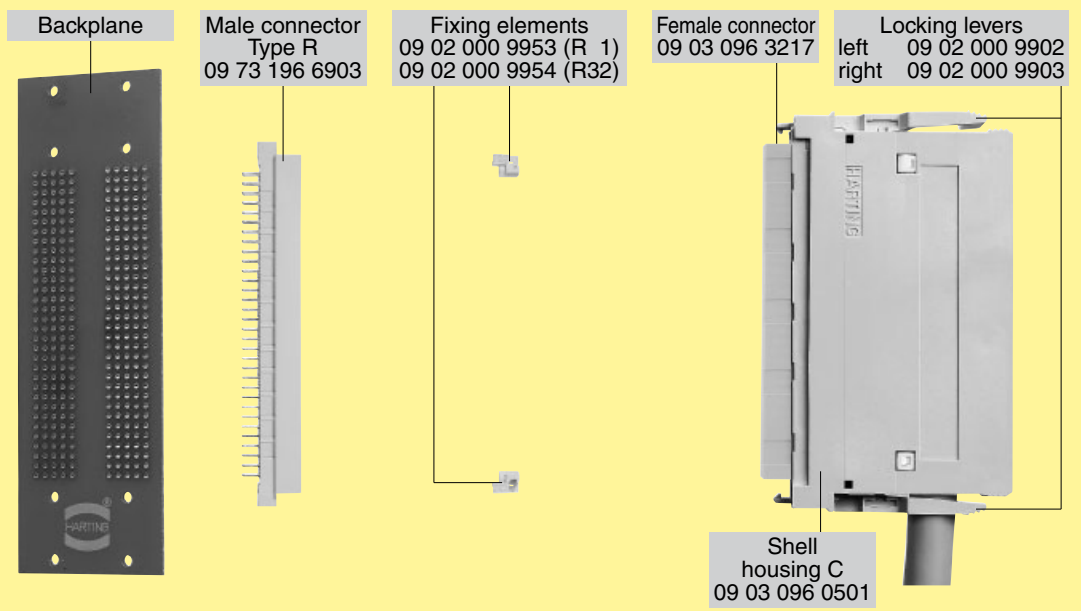

DIN Signal
up to 2 A

Application 5*

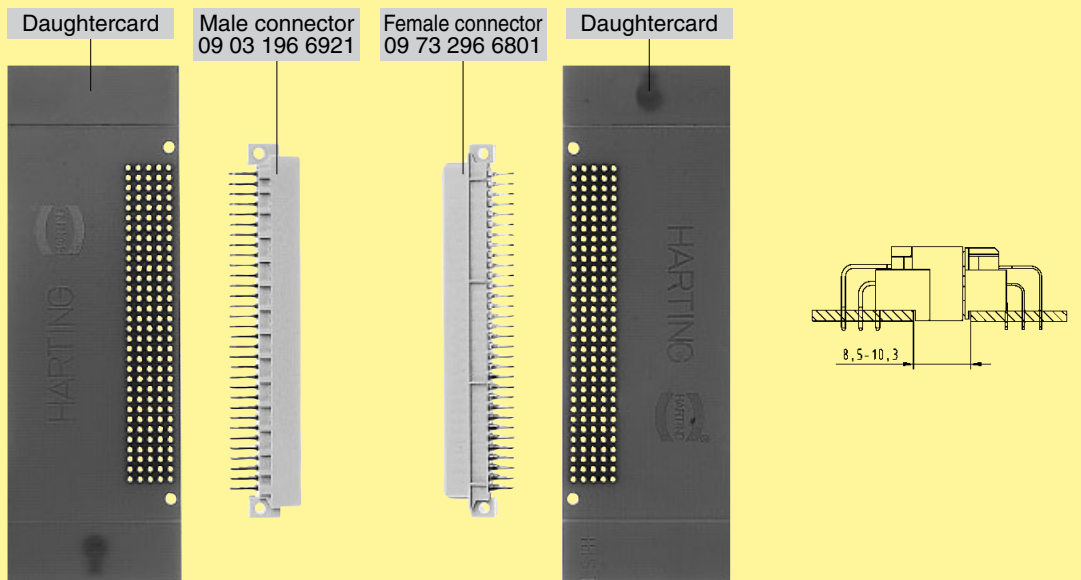

Application 6*

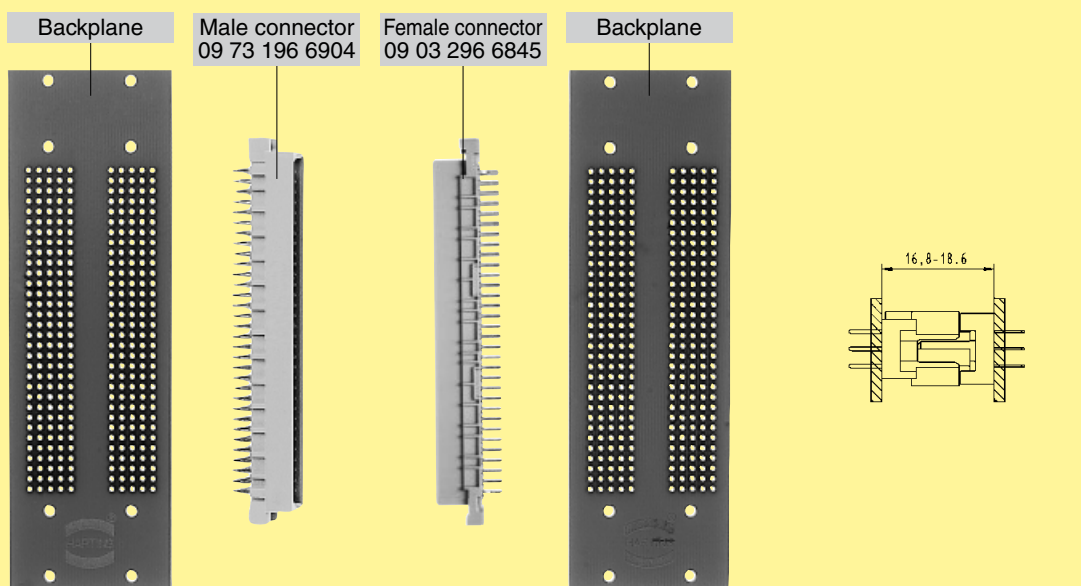

* Position marking turned: a1 contacts a32, a2 contacts a31, ...

Application 1

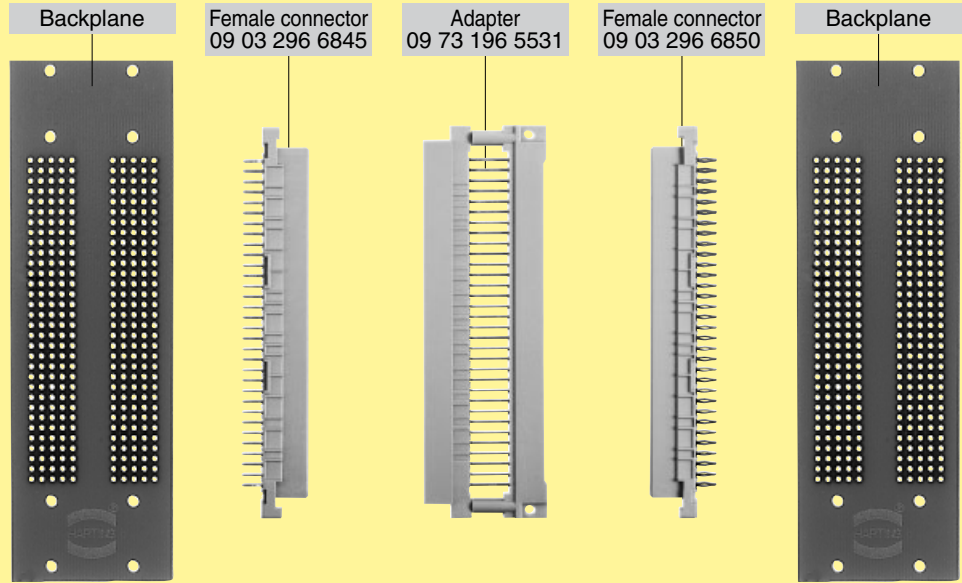
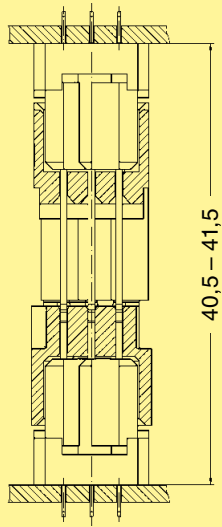

Application 2

