

Types H, H 3, MH 24 + 7, MH 21 + 5

Page

Technical characteristics type H

04.10

Type H connectors

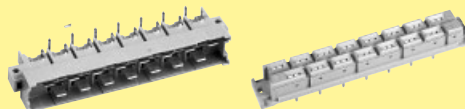

04.11

Type H 3 connectors



04.15

Technical characteristics type MH

04.20

Type MH 24 + 7 connectors

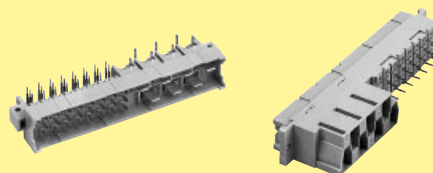

04.22

Type MH 21 + 5 connectors

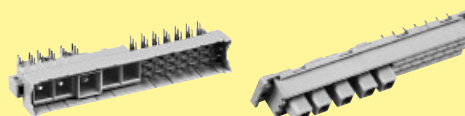

04.24

DIN Power
up to 15 A

Number of contacts
 15
 14 + 1 leading contact
 (position z 32)
 13 + 2 leading contacts
 (position z 4 und z 32)
 3

Working current 15 A max.
 see current carrying capacity chart

Clearance Type H: ≥ 4.5 mm
 Type H 3: ≥ 4.0 mm

Creepage Type H: ≥ 8.0 mm
 Type H 3: ≥ 3.7 mm

Working voltage
 The working voltage also depends on the clearance and creepage dimensions of the pcb itself and the associated wiring according to the safety regulations of the equipment Explanations see chapter 00
 Connectors should not be mated under voltage

Test voltage $U_{r.m.s.}$ Type H: ≥ 3.1 kV
 Type H 3: ≥ 2.5 kV

Contact resistance ≤ 8 m Ω

Insulation resistance $\geq 10^{12}$ Ω for standard articles
 $\geq 10^{11}$ Ω for special NFF articles (with part-no. ending 222)

Temperature range -55 $^{\circ}\text{C}$... $+125$ $^{\circ}\text{C}$
 The higher temperature limit includes the local ambient and heating effects of the contacts under load

Electrical termination
 Connector with faston 6.3 x 2.5 (faston blade width x wire gauge) according to DIN 46 245 and DIN 46 247
 Solder pins for pcb connections $\varnothing 1.6 \pm 0.1$ mm DIN EN 60 097
 Cage clamp terminal 0.14-1.5 mm²

Insertion and withdrawal force
 Type H: ≤ 90 N
 Type H 3: ≤ 20 N

Materials
 Mouldings Thermoplastic resin, glass-fibre filled, UL 94-V0
 Contacts Copper alloy

Contact surface
 Contact zone Hard silver plated or gold plated

Mating conditions see chapter 00
 Coding systems see chapter 00

Current carrying capacity

The current carrying capacity is limited by maximum temperature of materials for inserts and contacts including terminals. The current capacity curve is valid for continuous, non interrupted current loaded contacts of connectors when simultaneous power on all contacts is given, without exceeding the maximum temperature.

Control and test procedures according to DIN IEC 60 512

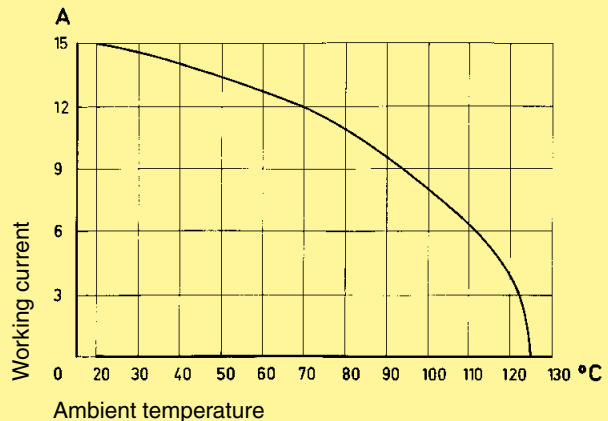

Low currents and voltages

Type H standard contacts have a silver plated surface. This precious metal has excellent conductive properties. In the course of a contact's lifetime, the silver surface generates a black oxide layer due to its affinity to sulphur. This layer is smooth and very thin and is partly interrupted when the contacts are mated and unmated, thus guaranteeing very low contact resistances. In the case of very low currents or voltages small changes to the transmitted signal may be encountered. This is illustrated below where an artificially aged contact representing a twenty year life is compared with a new contact.

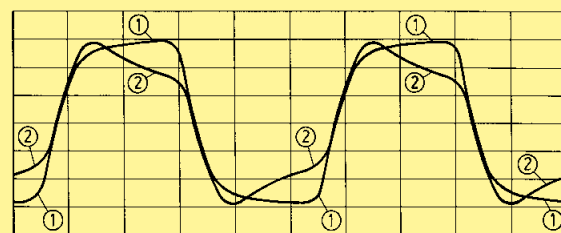

Changes to the transmitted signal after artificial ageing
 ① new contact ② after ageing

In systems where such a change to the transmitted signal could lead to faulty functions and also in extremely aggressive environments, HARTING recommend the use of gold plated contacts.

Below is a table derived from actual experiences.

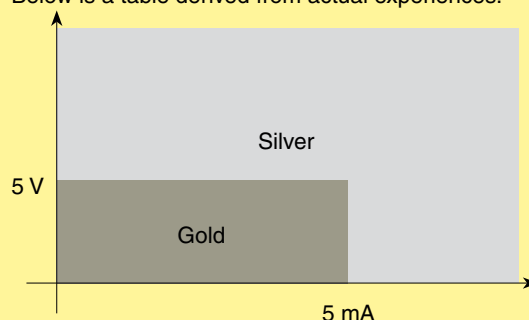

Recommendation

Number of contacts

15

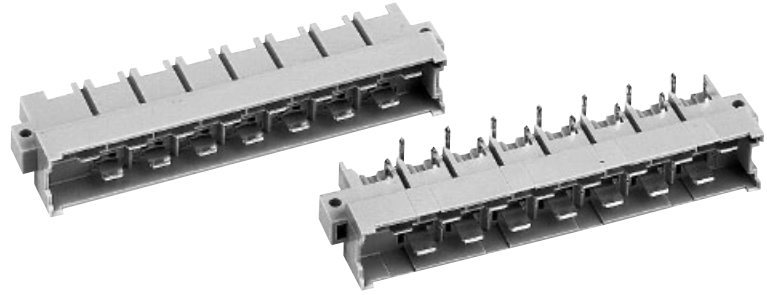

Male connectors

Identification	Number of contacts	Part No.	Drawing	Dimensions in mm
<p>Male connector for faston 6.3 x 2.5</p> <p>1 leading contact (position z 32)</p> <p>2 leading contacts (position z 4 + z 32)</p>	<p>15</p> <p>14 + 1</p> <p>13 + 2</p>	<p>Performance level 1 acc. to IEC 60603-2</p> <p>09 06 015 2912¹⁾</p> <p>09 06 015 2931¹⁾</p> <p>09 06 015 2922¹⁾</p>	<p>94 max.</p> <p>6.5</p> <p>5.08</p> <p>7.62</p> <p>14 x 5.08 = 71.12</p> <p>14.8 ± 0.2</p> <p>6.3 x 0.8</p> <p>88.9</p> <p>2.5</p> <p>6</p> <p>3.85</p> <p>4.8 x 0.8</p> <p>85.4</p> <p>87.5</p> <p>8.4 ± 0.3</p> <p>12.7</p> <p>25.1</p> <p>32</p> <p>30</p> <p>32</p> <p>30</p> <p>Board drillings</p> <p>2.8⁺⁰</p> <p>2.75⁺⁰</p> <p>88.9⁺⁰</p>	
<p>Male connector with angled solder pins³⁾</p> <p>1 leading contact (position z 32)</p> <p>2 leading contacts (position z 4 + z 32)</p>	<p>15</p> <p>14 + 1</p> <p>13 + 2</p>	<p>09 06 115 2911¹⁾</p> <p>09 06 115 2911 222¹⁾</p> <p>09 06 115 2932¹⁾</p> <p>09 06 115 2932 222¹⁾</p> <p>09 06 115 2921¹⁾</p> <p>09 06 115 2991²⁾</p>	<p>94 max.</p> <p>6.5</p> <p>5.08</p> <p>7.62</p> <p>14 x 5.08 = 71.12</p> <p>14.8 ± 0.2</p> <p>6.3 x 0.8</p> <p>88.9</p> <p>2.5</p> <p>6</p> <p>3.0</p> <p>3.85</p> <p>4.8 x 0.8</p> <p>85.4</p> <p>87.5</p> <p>8.4 ± 0.3</p> <p>12.7</p> <p>25</p> <p>32</p> <p>30</p> <p>32</p> <p>30</p> <p>Board drillings</p> <p>2.8⁺⁰</p> <p>2.75⁺⁰</p> <p>88.9</p> <p>5.08</p> <p>5.08</p> <p>16⁺⁰</p> <p>14 x 5.08 = 71.12</p> <p>12.7</p> <p>78.5</p> <p>5.08</p> <p>5.08</p> <p>all holes 4.0⁺⁰</p> <p>32 30 28 26 24 22 20 18 16 14 12 10 8 6 4</p>	
<p>Male connector with straight solder pins</p> <p>1 leading contact (position z 32)</p>	<p>15</p> <p>14 + 1</p>	<p>09 06 015 2913¹⁾</p> <p>09 06 015 2914¹⁾</p>		

DIN Power up to 15 A

04
ti

¹⁾ Variant with silver plated contacts
²⁾ Variant with gold plated contacts
³⁾ With shroud coding, see chapter 00

¹⁾ Railway classification NFF 16-101, Smoke index: F1, Flammability class: I2

Number of contacts

15

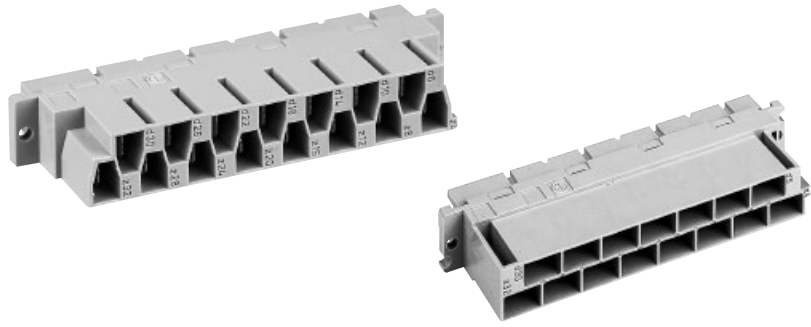

Female connectors

Identification	Number of contacts	Part No.	Drawing	Dimensions in mm
<p>Female connector for faston 6.3 x 2.5¹⁾</p> <p>Cannot be used in a shell housing</p>	15	<p>Performance level 1 acc. to IEC 60603-2</p> <p>09 06 215 2811</p>	<p>Contact arrangement View from termination side</p>	
<p>Female connector for faston 6.3 x 2.5¹⁾</p> <p>May be used in a shell housing</p>	15	<p>09 06 215 2871</p> <p>09 06 215 2871 222¹⁾</p>	<p>Contact arrangement View from termination side</p>	
Panel cut out				

DIN Power up to 15 A

¹⁾ With shroud coding, see chapter 00
¹⁾ Railway classification NFF 16-101, Smoke index: F1, Flammability class: I2

Number of contacts

15



Female connectors

Identification Number of contacts Part No. Drawing Dimensions in mm

Female connector with solder pins "low profile"³⁾

2.7 mm

15

Performance level 1 acc. to IEC 60 603-2

09 06 215 2812¹⁾

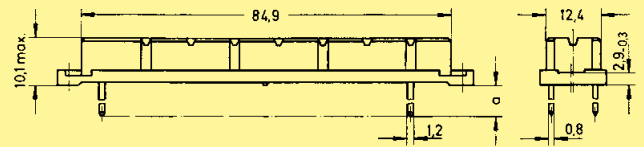

4 mm

15

09 06 215 2821¹⁾
09 06 215 2821 222^{1)f)}
09 06 215 2892²⁾

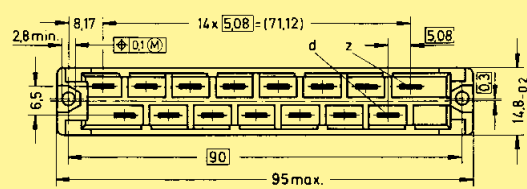

5.5 mm

15

09 06 215 2890²⁾

a
2.7
4
5.5
7
10

7 mm

15

09 06 215 2831¹⁾
09 06 215 2891²⁾

10 mm

15

09 06 215 2841¹⁾

Contact arrangement View from termination side

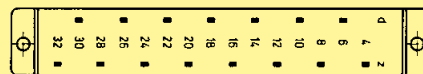

Board drillings
Mounting side

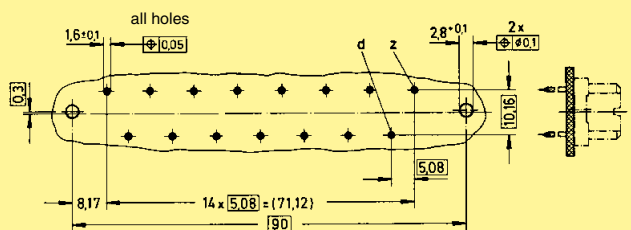

DIN Power up to 15 A

¹⁾ Variant with silver plated contacts
²⁾ Variant with gold plated contacts
³⁾ With shroud coding, see chapter 00

^{f)} Railway classification NFF 16-101, Smoke index: F1, Flammability class: I2

Number of contacts

15

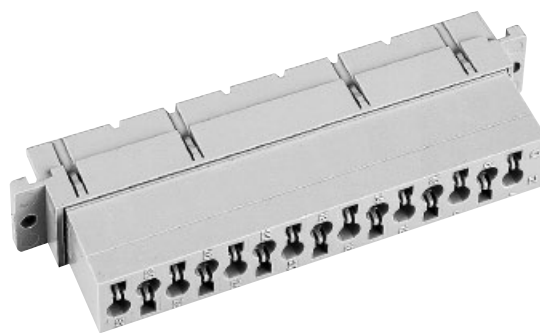

Female connectors

Identification Number of contacts Part No. Drawing Dimensions in mm

Female connector with cage clamp

May be used in a shell housing

15

Performance level 1 acc. to IEC 60 603-2

09 06 015 2813¹⁾

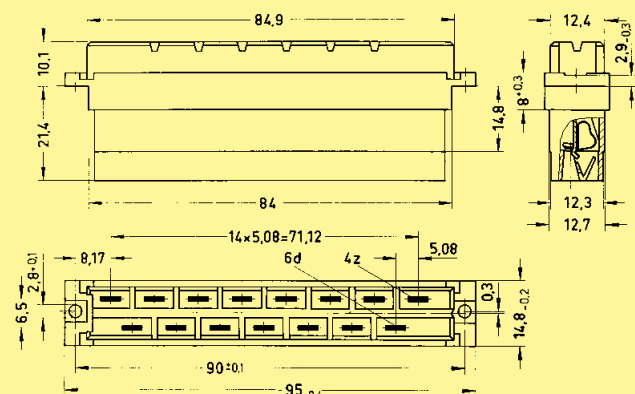

Contact arrangement View from termination side

Slot for screw driver

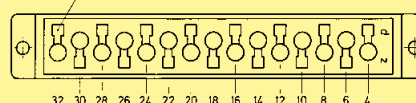

Shell housing see chapter 20

Panel cut out

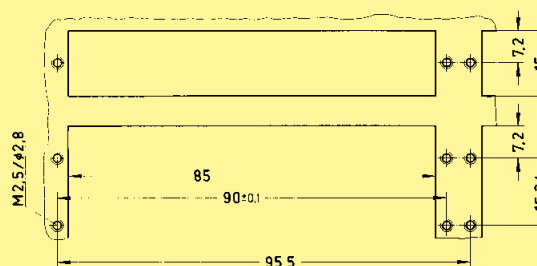

Termination instructions

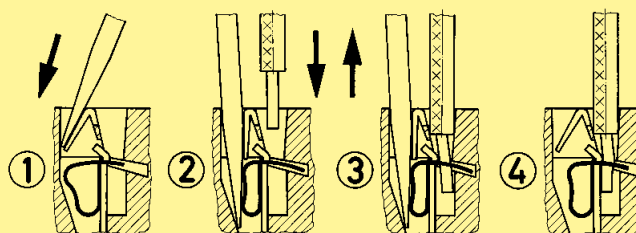

Screw driver width: 2.5 x 0.4 mm
 Stripping length: 4 - 7 mm
 Wire gauge: 0.14 - 1.5 mm² (AWG 26 - 16)

DIN Power up to 15 A

04
14

¹⁾ Railway classification NFF 16-101, Smoke index: F1, Flammability class: I2

Number of contacts

3



Male and female connectors

Identification	Number of contacts	Part No.	Drawing	Dimensions in mm
----------------	--------------------	----------	---------	------------------

Male connector with angled solder pins and preleading middle contact

3

Performance level 1 acc. to IEC 60603-2

09 06 203 2911

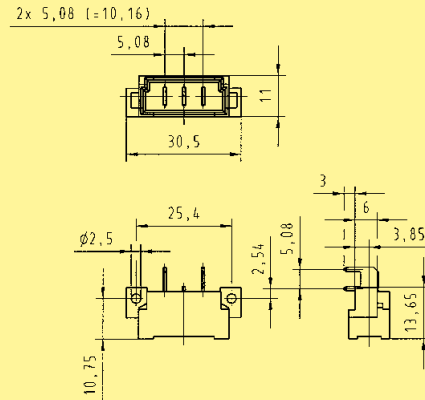

Board drillings

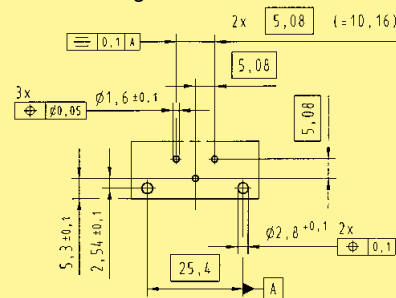

Female connector with solder pins

3

09 06 203 2811

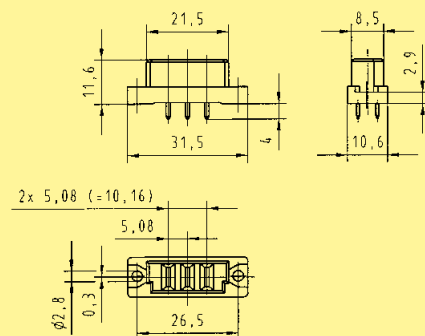

Board drillings

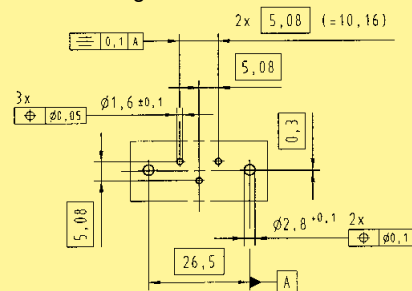

ELECTRONIC SECTION

Number of contacts	21, 24 + 7
Contact spacing (mm)	
Male connector	2.54 x 5.08
Female connector	5.08
Working current	6 A max.
see current carrying capacity chart	
Clearance	≥ 1.6 mm
Creepage	≥ 3 mm
Working voltage	
The working voltage also depends on the clearance and creepage dimensions on the pcb itself, and the associated wiring	according to the safety regulations of the equipment. Explanations see chapter 00
Test voltage $U_{r.m.s.}$	1.55 kV
Contact resistance	≤ 15 mΩ wrap, solder termination ≤ 20 mΩ including crimp connection
Electrical termination	Solder pins for pcb connection Ø 1 ± 0.1 mm acc. to IEC 60 326-3 Wrap posts 1 x 1 mm diagonal 1.34-1.45 mm Crimp terminal 0.09-1.5 mm ²
Contact surface	
Contact zone	Selectively plated according to performance level ¹⁾

HEAVY DUTY SECTION*

Number of contacts	7
Working current	15 A max.
see current carrying capacity chart	
Clearance	≥ 4.5 mm
Creepage	≥ 8.0 mm
Working voltage	
The working voltage also depends on the clearance and creepage dimensions on the pcb itself, and the associated wiring	according to the safety regulations of the equipment. Explanations see chapter 00
Test voltage $U_{r.m.s.}$	3.1 kV
Contact resistance	≤ 8 mΩ
Electrical termination	Connector for faston 6.3 x 2.5 (faston width x wire gauge) acc. to DIN 46 245 and DIN 46 247 Solder pins for pcb connection Ø 1.6 ± 0.1 mm acc. to DIN EN 60 097
Contact surface	
Contact zone	Hard silver plated

BOTH PARTS

Insulation resistance	≥ 10 ¹² Ω for standard articles ≥ 10 ¹¹ Ω for special NFF articles (with part-no. ending 222)
Temperature range	- 55 °C ... + 125 °C
The higher temperature limit includes the local ambient and heating effects of the contacts under load	

Insertion and withdrawal force ≤ 85 N

Materials

Mouldings	Thermoplastic resin, glass-fibre filled, UL 94-V0
Contacts	Copper alloy

Current carrying capacity

The current carrying capacity is limited by maximum temperature of materials for inserts and contacts including terminals. The current capacity curve is valid for continuous, non interrupted current loaded contacts of connectors when simultaneous power on all contacts is given, without exceeding the maximum temperature.

Control and test procedures according to DIN IEC 60 512

Electronic section

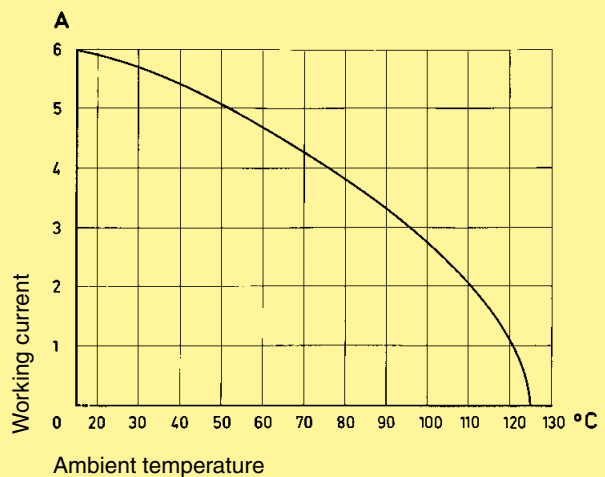

Heavy duty section

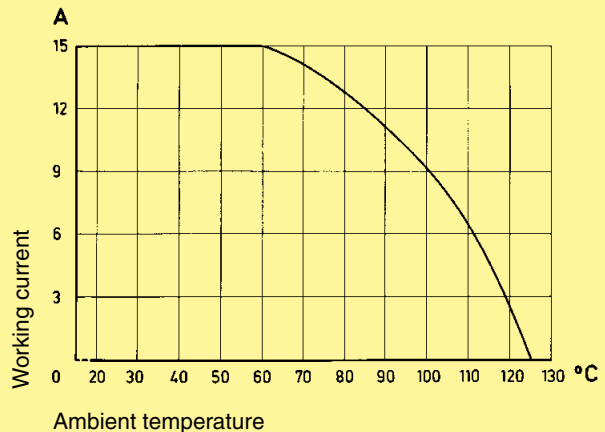

* only for type MH 24 + 7

¹⁾ Explanation of performance levels see chapter 00

Mating conditions see chapter 00
Coding systems see chapter 00

Number of contacts

24 + 7
F + H

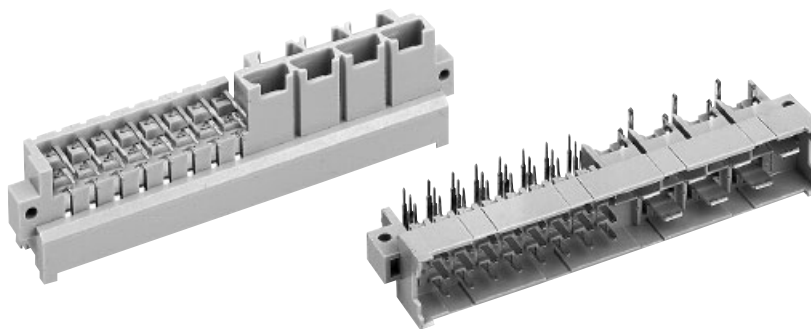

Male connectors

Identification	Number of contacts	Part No. Performance levels according to IEC 60 603-2. Explanation chapter 00		
		3	2	1
Male connector for faston 6.3 x 2.5	1 leading contact (position z 32)		09 06 031 6921 ¹⁾	09 06 031 2921 ¹⁾
	2 leading contacts (position z 2 + z 32)		09 06 031 6923 ¹⁾	
Male connector with angled solder pins ¹⁾	1 leading contact (position z 32)		09 06 131 6922	
	2 leading contacts (position z 2 + z 32)		09 06 131 6924 09 06 331 6924 ^{b)}	

DIN Power up to 15 A

Faston terminal

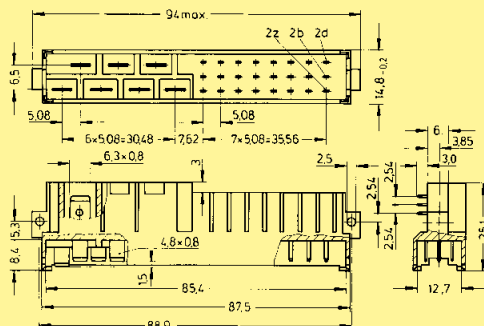

Angled solder pins

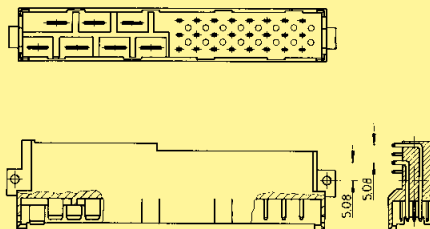

Board drillings

Mounting side

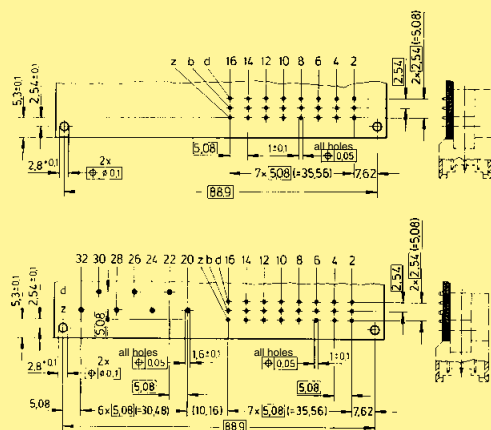

Contact arrangement

View from termination side

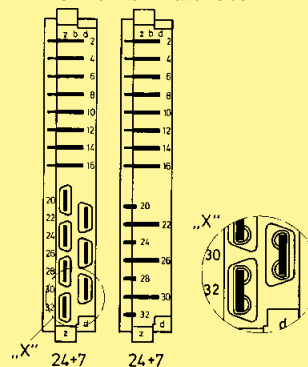

Dimensions in mm

¹⁾ With shroud coding, see chapter 00

^{b)} Connector with fixing clip see chapter 00

¹⁾ Railway classification NFF 16-101, Smoke index: F1, Flammability class: I2

Number of contacts

24 + 7
F + H

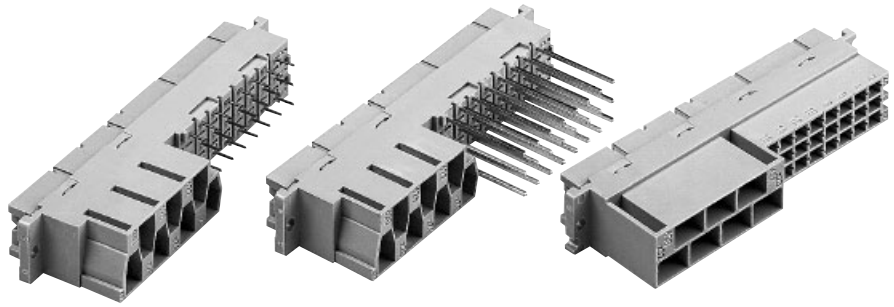

Female connectors

Identification	Number of contacts	Part No.		
		3	2	1
Female connector with solder pins 4.5 mm ¹⁾	24 + 7		09 06 231 6822 09 06 231 6822 222 ^{f)}	09 06 231 2822
Female connector with wrap posts 1 x 1 mm ¹⁾	24 + 7		09 06 231 6821	09 06 231 2821 09 06 231 2821 222 ^{f)}
Female connector for crimp contacts ¹⁾ Order contacts separately, see chapter 03	24 + 7			09 06 231 2881 09 06 231 2881 222 ^{f)}

DIN Power up to 15 A

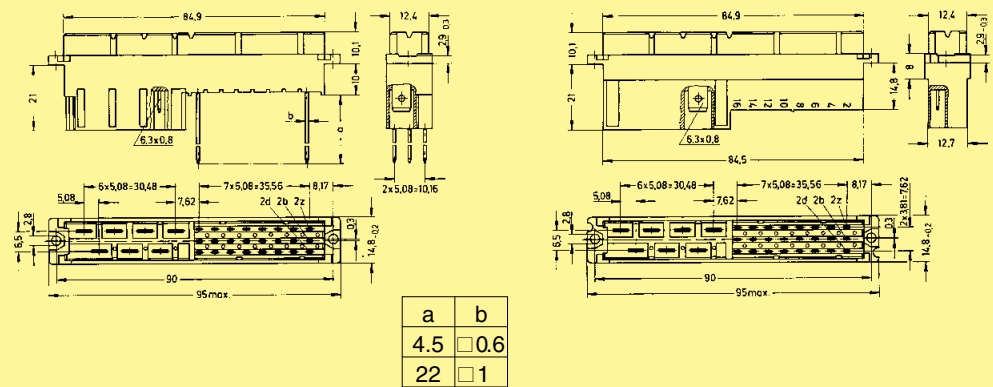

Panel cut out

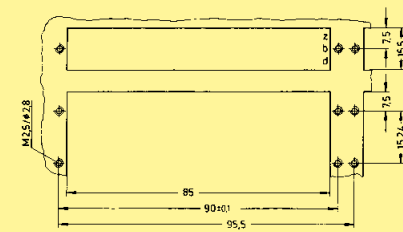

Contact arrangement
View from termination side

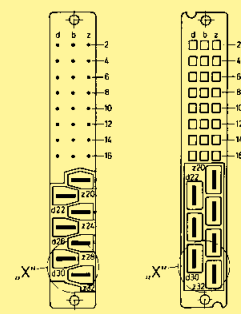

Board drillings
Mounting side

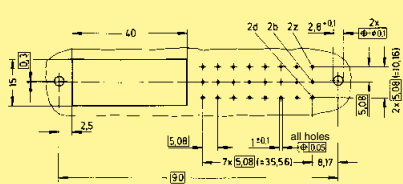

Shell housing for female connector with crimp contacts see chapter 20

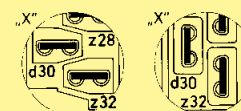

Dimensions in mm

¹⁾ With shroud coding, see chapter 00

^{f)} Railway classification NFF 16-101, Smoke index: F1, Flammability class: I2

DIN 41 612 · complementary type MH



Number of contacts

21 + 5
F + M

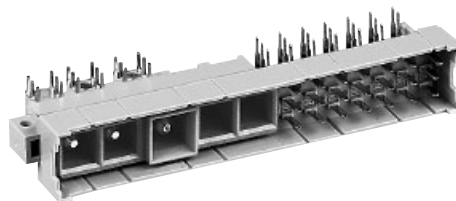

Male connectors

Identification	Number of contacts	Part No. 3	Performance levels according to IEC 60 603-2. Explanation chapter 00 2	1
Male connector with angled solder pins (without special contacts)*	21 + 5	Performance level 3 on request	09 06 121 6981	Performance level 1 on request
High current contact for printed circuit terminations max. 40 A ²⁾			09 03 000 6127	
leading contact max. 40 A ²⁾			09 03 000 6128	
Removal tool			09 99 000 0328	

Dimensions

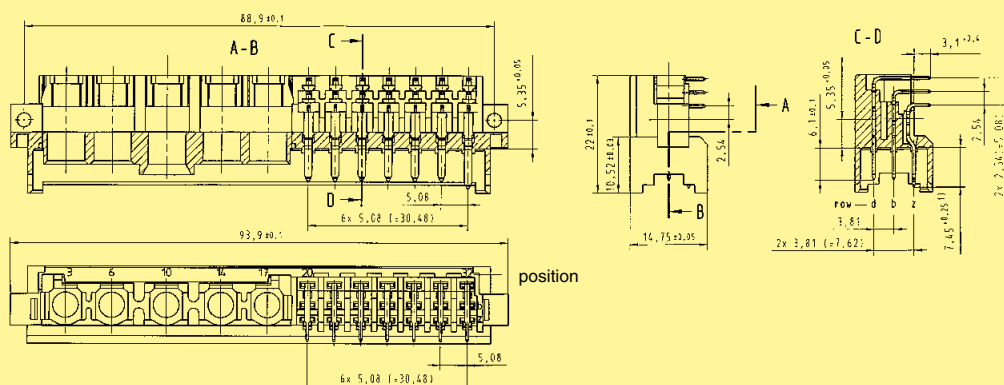

Board drillings

Mounting side

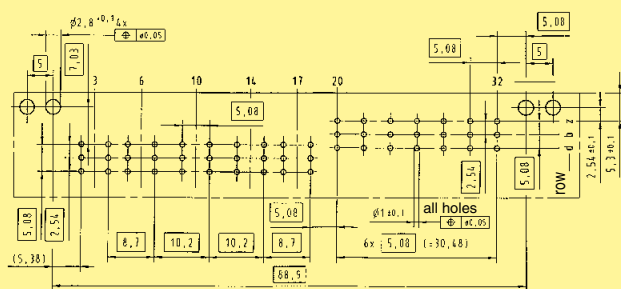

1) Leading contact in position z 32

Dimensions

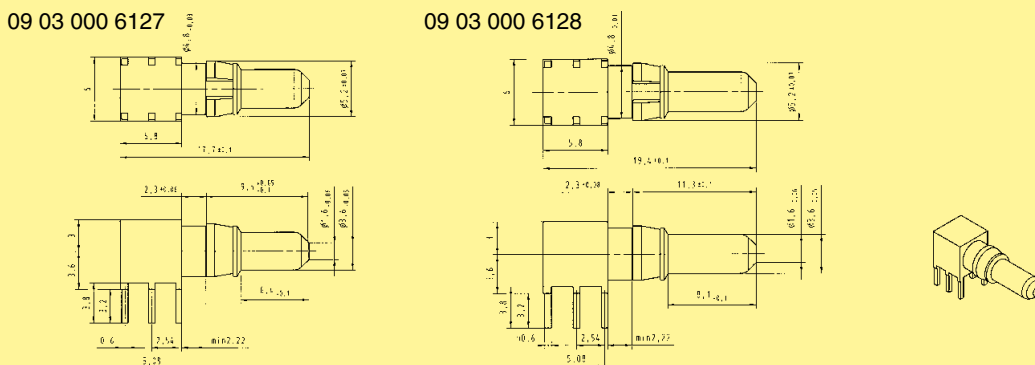

Dimensions in mm

* Pre-loaded with special contacts on request

Code keys see chapter 00

²⁾ Depending on the pcb design

Further special contacts see chapter 01

DIN 41 612 · complementary type MH



Number of contacts

21 + 5
F + M

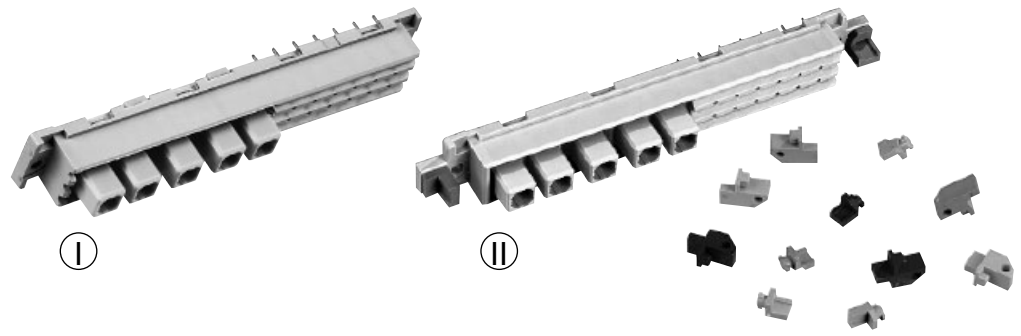

Female connectors

Identification	Number of contacts	Part No. 3	Performance levels according to IEC 60 603-2. Explanation chapter 00 2	1
Female connector with solder pins 3.2 mm (without special contacts)	without flange coding (I)	Performance level 3 on request	09 06 221 6883	Performance level 1 on request
	with flange coding ¹⁾ (II)		09 06 721 6883	
High current contact Crimp contacts for printed circuit termination 20 A			09 03 000 6220	

Dimensions

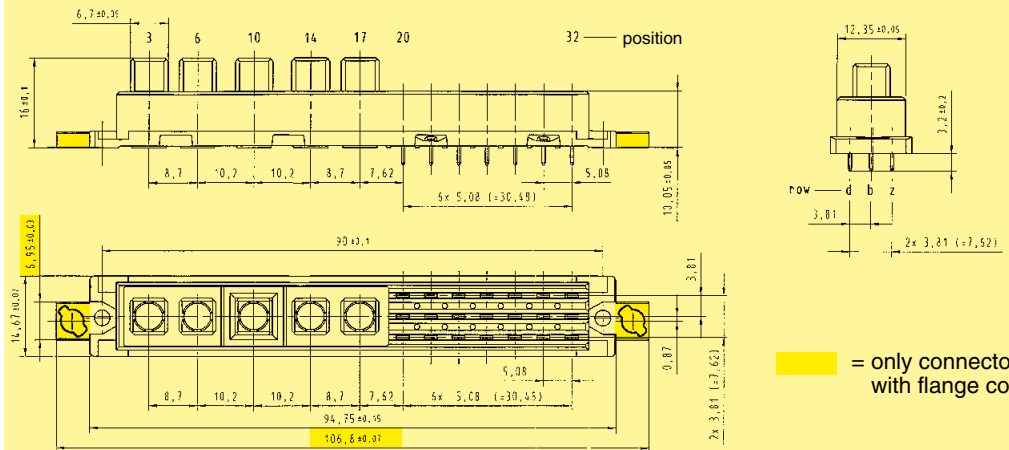

Board drillings Mounting side

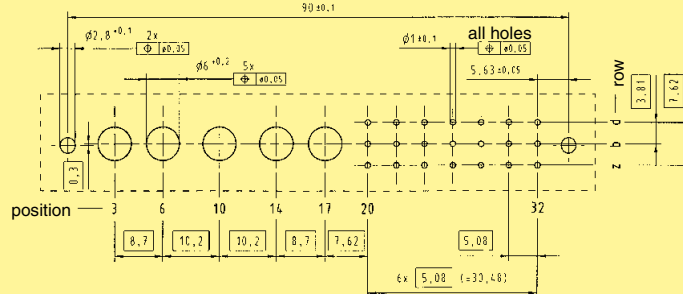

Dimensions

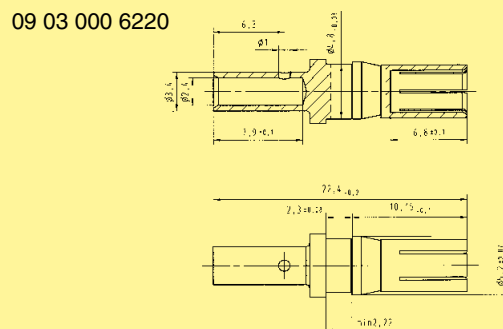

Dimensions in mm

DIN Power
up to 15 A

■ = only connectors with flange coding

¹⁾ Code keys see chapter 00
Removal tool for contacts is available with part number 09 99 000 0174

Further special contacts see chapter 01